

Camera Link UV CMOS Camera

ARTCAM-2020UV-CL

INSTRUCTION BOOKLET

4.00 M Pixels

ARTCAM-2020UV-CL

ARTRAY CO., LTD.

ARTRAY

Contents

| | |
|---|--------|
| 1. Attention..... | - 3 - |
| 2. Introduction..... | - 6 - |
| 3. Main Features..... | - 6 - |
| 4. The Product..... | - 6 - |
| 5. Setup..... | - 7 - |
| 5.1. Connecting Method (an example)..... | - 7 - |
| 5.1.1. When using on a desktop PC | - 7 - |
| 5.1.2. When using on a notebook PC..... | - 7 - |
| 6. Specifications..... | - 8 - |
| 6.1. Camera Specification..... | - 8 - |
| 6.1.1. Camera specification list | - 8 - |
| 6.1.2. Dimensional Outline | - 9 - |
| 6.1.3. Schematic Diagram of the Sensor | - 10 - |
| 6.2. Camera's Functions | - 11 - |
| 6.2.1. Shutter Speed | - 11 - |
| 6.2.2. External Trigger Function..... | - 11 - |
| 7. Spectral Sensitivity Characteristics | - 13 - |
| 7.1. ARTCAM-2020UV-CL | - 13 - |
| 7.2. UV Bandpass Filter (U340) (Optional) | - 13 - |
| 8. Recommended System Requirements | - 14 - |

1. Attention

■About this manual

1. Before using the camera, please read this manual thoroughly.
2. Please keep this manual reachable and always refer to the contents when needed.
3. Please contact us if the manual is lost or damaged. We will provide a replacement.
4. We cannot guarantee the safety of improper uses of the camera.
5. For your safety, please follow the directions of this manual.
6. All contents are subject to change.
7. Images in this manual may have been simplified to be easier comprehended.
8. Please contact us if you find any unclear points or mistakes in this manual.
9. Quoting, copying or altering some or all parts of the manual without our permission is prohibited.
10. We are not responsible for any lost or damages on your profits due to the use of our products.
11. Please understand that our oversea branches do not provide maintenance or repair services.

■About the Icons

To keep the safety of the user, other people and their properties, please pay attention to the following icons.



Warning

If the user fails to follow the instruction, serious injury or death may occur.



Caution

If the user fails to follow the instruction, physical injury on human or damages on hardware may occur.

■For Safe Use



Warning

●In following circumstances, please stop using the product and turn off the power immediately to prevent the risks of fires and electric shocks. If the product is defective, please contact us for repair or exchange. For your safety, please do not disassemble, modify or repair the camera on your own.

Please stop using the product and turn off the power immediately when:

- The product becomes smoky or gets extremely hot on the surface, or makes unusual smells or sounds.
- Foreign material or water gets into the product.
- The product falls and becomes damaged.

●Do not place the product on unstable surfaces. The product may be fallen and people may get hurt.



Caution

●Do not expose the product to steam or fumes to avoid electric shocks and fires.

●Do not leave the product in high temperature places such as inside of vehicles or under direct sunlight. High temperature may cause damages to the camera, or even cause fires.

●Do not cover the product with cloth or other materials. The product may get extremely hot and the heat may cause deformations on the parts or even cause fires.

●Please avoid dropping or shocking the product as the product may be damaged.

●Do not touch the cable with a wet hand. Such action may cause electric shocks.

●Please avoid continuously contacting the surface of the camera to your skin when the camera is being used. The surface temperature of the camera may cause burns.

■Other Notices

●Please do not use the camera under strong lights such as sun light for a long period. Also please do not expose the camera under strong lights even when the product is not being used because the sensor might be damaged.

Maintenance

● Wipe the dirt on surface with soft cloth or tissue paper. Do not use alcohol, thinner or benzene to avoid damaging the surface paints.

Electro Magnetic Interference

●The camera may interference with electronic devices such as TV and radio. Please do not place the camera next to such equipment.

■Export Control

The Government of Japan controls military sensitive goods and technologies including relevant dual-use goods and technologies.

This product is a Catch-all Control item subject to the Foreign Exchange and Foreign Trade Act and its relevant legislations. Except for exporting to the 26 white countries designated in the Cabinet Order, export licenses are required if the products are going to be used for military use or if the end user of the product is related to all kinds of military activities. If your circumstances cause the need to apply export licenses, please notify us before you place orders. Also, please notify us in advance if the end users or purposes of use change after the purchase and thus cause the need to apply export licenses.

*The 26 white countries not under the UNSC Arms Embargo:

Argentina, Australia, Austria, Belgium, Bulgaria, Canada, Czech Republic, Denmark, Finland, France, Germany, Greece, Hungary, Ireland, Italy, Luxemburg, Netherlands, New Zealand, Norway, Poland, Portugal, Spain, Sweden, Switzerland, United Kingdom, and United States

About the Japanese Security Export Controls, please refer to the webpage for Security Export Control Policy, The Ministry of Economy, Trade and Industry:

<http://www.meti.go.jp/policy/anpo/englishpage.html>

■Guarantee

To save the environment, we do not issue warranty in printed format. Instead, all records of the warranty periods, delivery dates and the customer information are well kept in our system.

For more details, please refer to the sites below:

Hardware Warranty: http://www.artray.us/download/artray_warranty.pdf

2. Introduction

ARTCAM-2020UV-CL is a series of ultraviolet cameras with high sensitivity to the wavelength band of 200 nm to 1100 nm.

3. Main Features

- UV Detection with High Sensitivity

The CMOS sensor can detect radiation invisible to human eyes and CMOS cameras in the wavelength range between 200 nm to 1100 nm band.

- CameraLink interface

We adopt high reliability CameraLink interface as industrial application.

4. The Product

- 1) Camera
- 2) AC adapter (AC100-240V -> DC12V)
- 3) Software CD

<Options>

- 1) Grabber board (PIXCI-EB1, manufactured by EPIX, Inc., is recommended.)
- 2) CameraLink Cable (Standard 5m, Exchangeable to 1m or 3m)
- 3) CameraLink SDK (XCLIB manufactured by EPIX, etc.)

5. Setup

5.1. Connecting Method (an example)

5.1.1. When using on a desktop PC

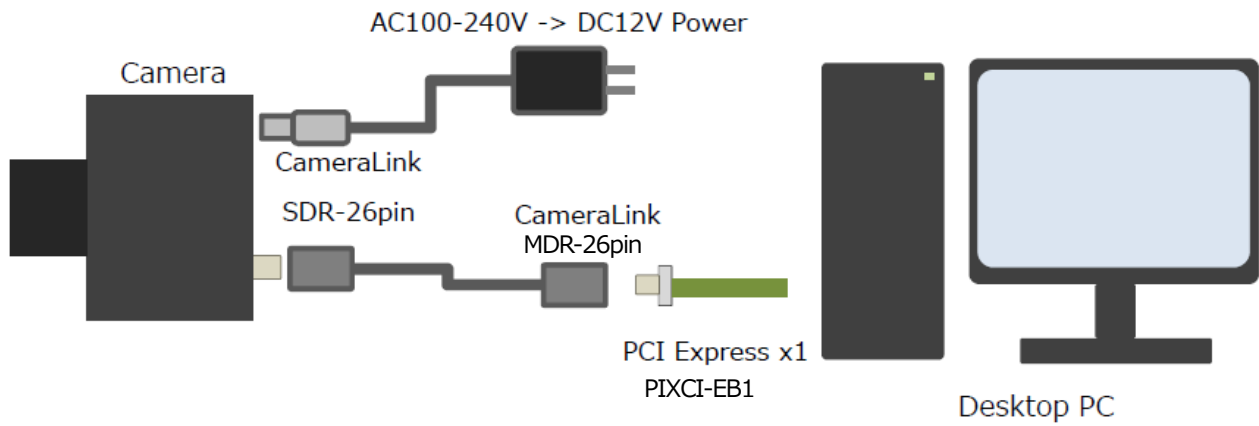

5.1.2. When using on a notebook PC

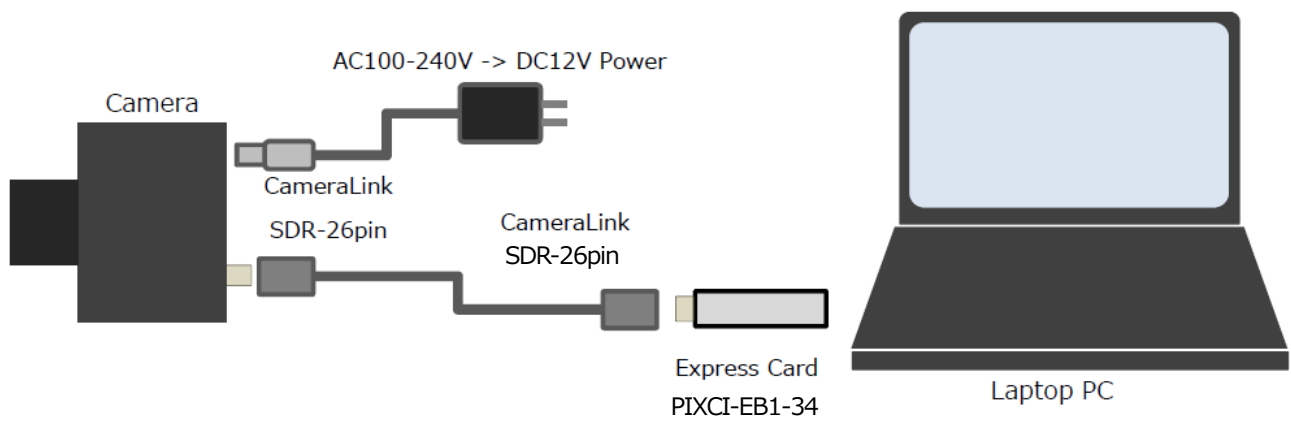

*There is a unique port of CameraLink channel used since this camera operates with CameraLink - Base Configuration.

For the connector of this camera is SDR-26pin, please use the supported cable.

6. Specifications

6.1. Camera Specification

6.1.1. Camera specification list

| Items | |
|-------------------------------------|---|
| Image pickup device | Gpixel 4.0M pixels CMOS Sensor GSENSE2020BSI |
| Number of total pixels | 2056(W) x 2058(H) |
| Number of effective pixels | 2048(W) x 2048(H) |
| Pixel Size | 6.5(H) [μ m] x 6.5(V) [μ m] |
| Imaging area | 13.3(H)x13.3(V)[mm] (Diagonal 18.809[mm], Approx.1.2 inch) |
| Detection frequency band | 200~1100nm |
| Shutter Type | Rolling Shutter (Global reset possible) |
| Saturation capacity / readout noise | 54ke- 1.6e- @12/11bits |
| A/D Resolution | 11/12bits |
| Interface | Camera Link (Base Configuration) |
| Number of output bits | 12 bits |
| Frame Rate | 23 fps |
| Shutter Speed | 11.2 μ sec ~ 1 sec |
| Synchronization System | Internal Synchronization / External Trigger Synchronization |
| Lens Mount | C Mount |
| External I/O terminal | HR10A-7R-6S(73) (HIROSE) |
| Power | DC12V External input |
| Power Consumption | Approx.6W (During normal operation) |
| Ambient Conditions | Operating Temperature/Humidity : 0~35°C/10~80%(Non condensing) Storage Temperature/Humidity : 0~60°C /10~95%(Non condensing) |
| External Dimensions | 71.6(W) x 61.5(H) x 51.5(D) mm ※Exclude lens, tripod mount and projections |
| Weight | Approx. 240g ※Exclude lens, tripod mount and projections |

※All by nominal value

6.1.2. Dimensional Outline

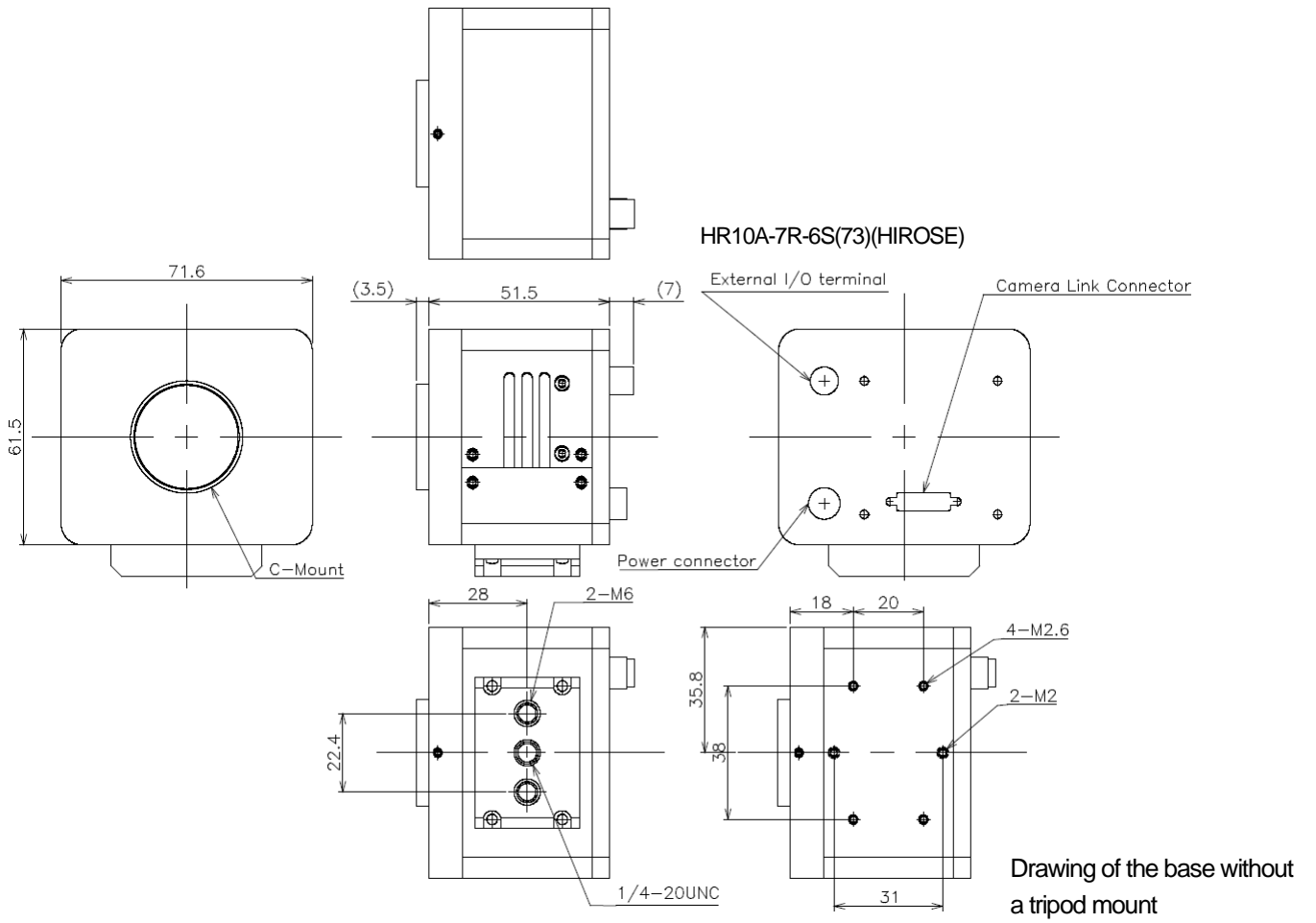

6.1.3. Schematic Diagram of the Sensor

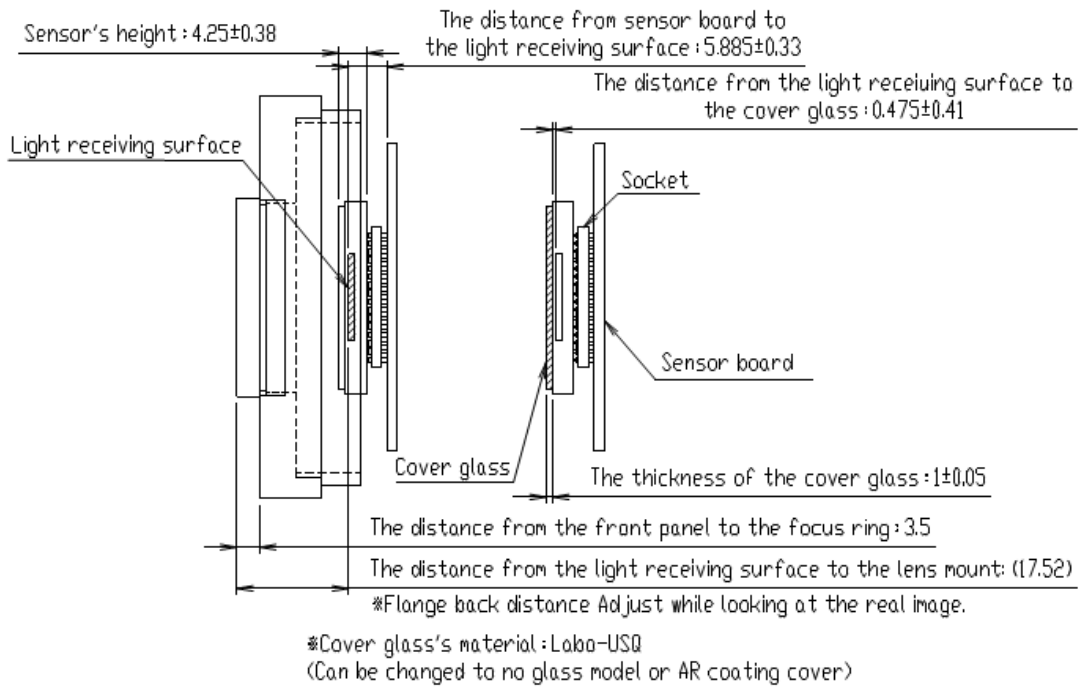

6.2. Camera's Functions

6.2.1. Shutter Speed

The exposure time (electronic shutter speed) of the camera can be set.

The exposure time can be calculated by the following formula:

Exposure time = the setting value of the shutter speed * 1 H period

※1 H period = 560(Minimum) * 1PCLK = 11.2μsec.

※1PCLK = 1/50,000,000sec. = 0.020μsec.

6.2.2. External Trigger Function

This camera has an external trigger electronic circuit, which is insulated by a photocoupler, and thus enables synchronized shooting by the input signal received from the external circuit.

Trigger input circuit diagram

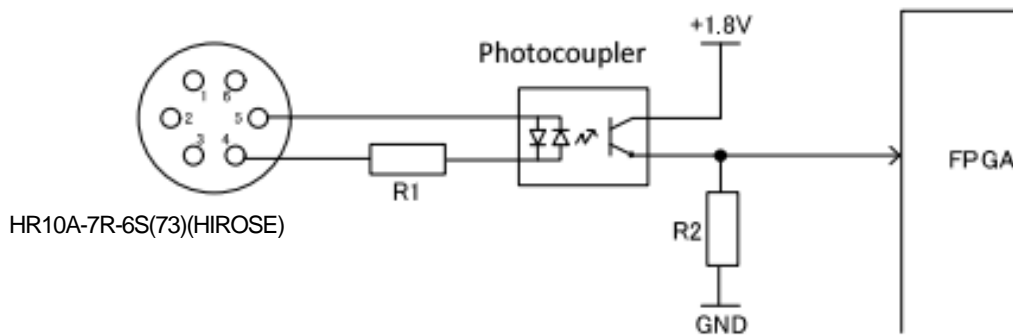

R1 = 2.4kΩ (5~12V)

R2 = 4.7kΩ

The Pin Assignment of the External I/O Terminal

| Pin Number | Function |
|------------|--|
| 1 | GND |
| 2 | External output 1 (Vertical Synchronization) ※ |
| 3 | External output 2 (Strobe) ※ |
| 4 | External Input (-) (Trigger Reception -) |
| 5 | External Input (+) (Trigger Reception +) |
| 6 | +12V |

※When outputting, please use open drain (6.5V, 50mA)

Details of trigger timing

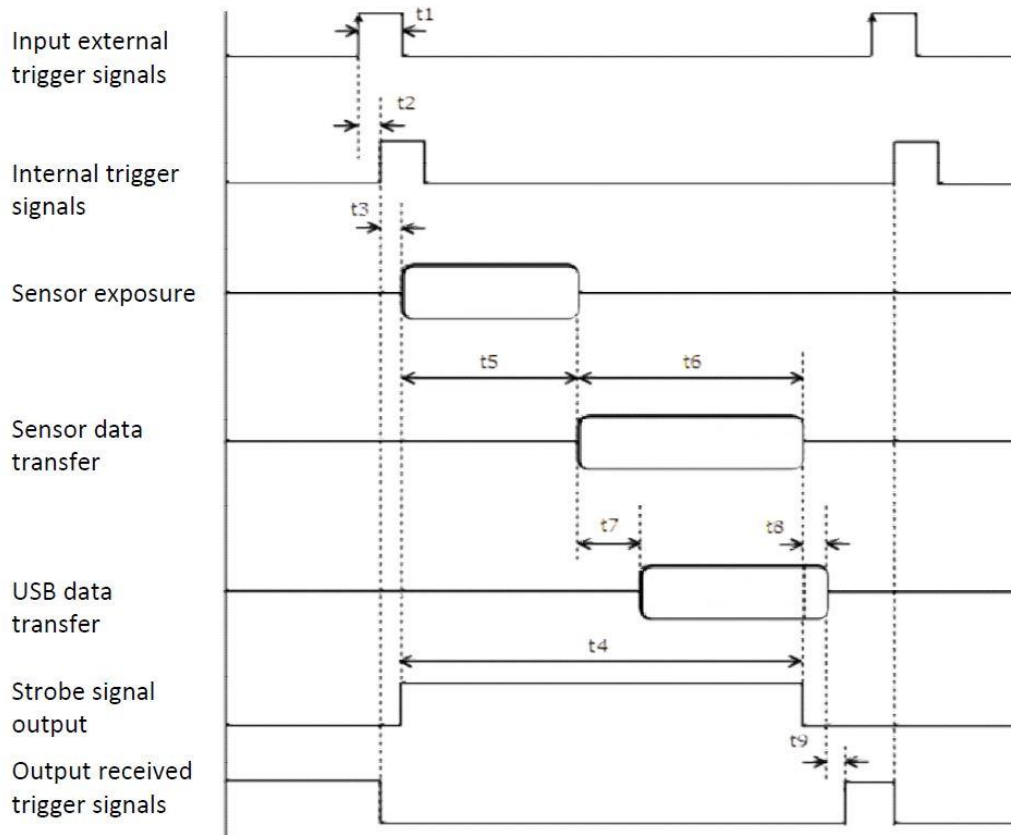

| Item Numbers | Items | Required Time |
|--------------|---|--|
| t1 | Effective Trigger Input Pulse | >10 μ sec. |
| t2 | Time required from the starting of the External Trigger to the starting of the Internal Trigger Signals (may delay caused by the photocoupler) | <1 μ sec. |
| t3 | Time required from the starting of the Internal Trigger Input to the Exposure Time | <1 μ sec. |
| t4 | Strobe Time | $t_5 + t_6$ |
| t5 | Exposure Time | Exposure Time = the setting value of the Shutter Speed * 1 H period ※1 H period = 560(Minimum) * 1PCLK = 11.2 μ sec. ※1PCLK = 1/50,000,000sec. = 0.020 μ sec. |
| t6 | Time required for data transfer (from the sensor to the FPGA) | (Effective Vertical Pixels + 2) * 1 H period |
| t7 | Time required for the transfer (from the FPGA to USB) | >3 H period |
| t8 | Time required from the completion of the sensor data transfer to the completion of the USB data transfer | >3 H period |
| t9 | Time required from the completion of the internal data transfer until the next trigger input becomes available | Approx. 1 H period |

7. Spectral Sensitivity Characteristics

7.1. ARTCAM-2020UV-CL

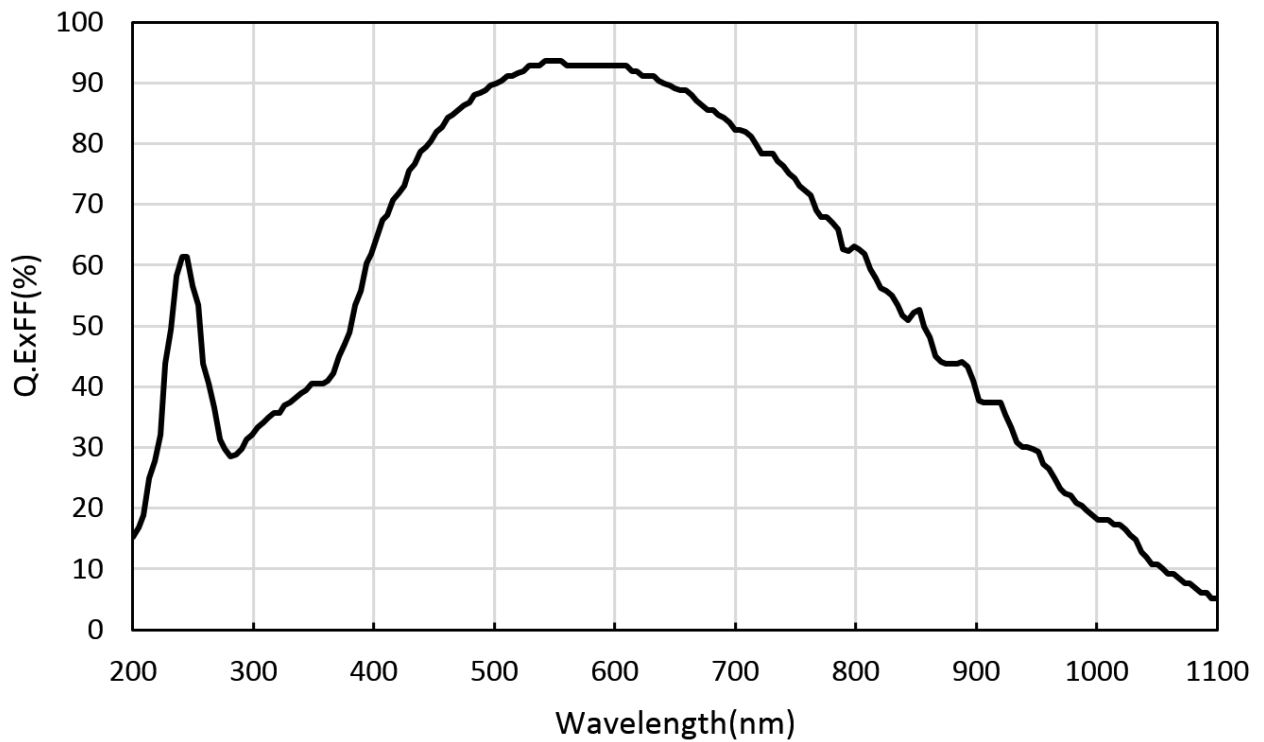

7.2. UV Bandpass Filter (U340) (Optional)

ARTCAM-2020UV-CL is possible to choose to install an additional filter U340, which can absorb visible wavelengths and only allow ultraviolet wavelengths to pass.

Please refer to the following Spectral sensitivity line chart for detail.

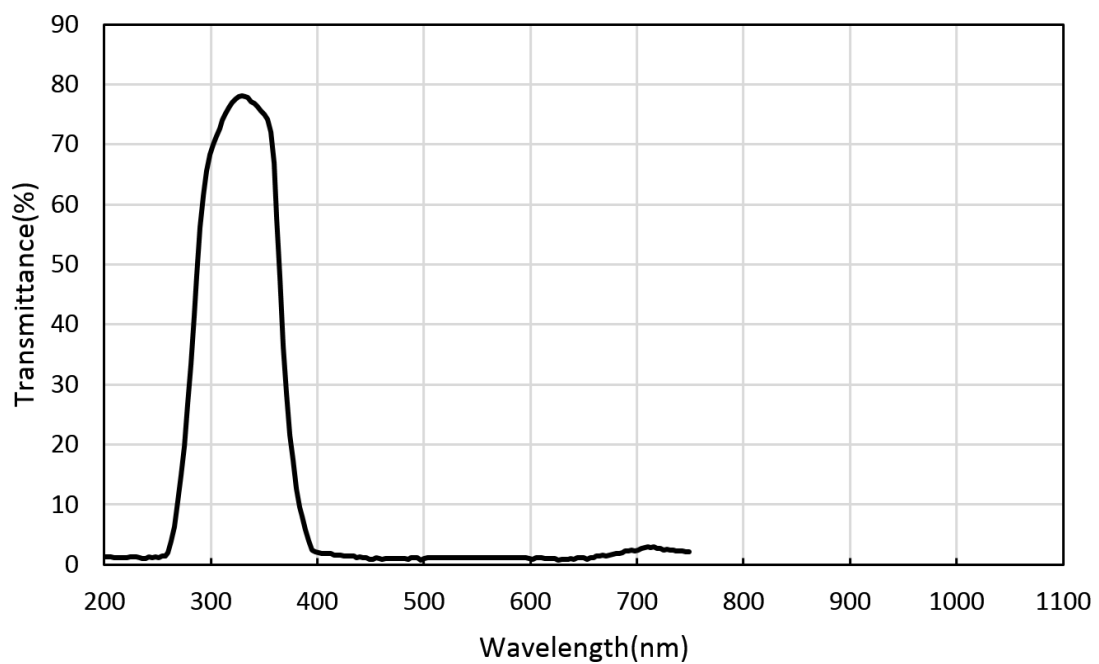

8. Recommended System Requirements

- Camera Link Frame Grabber

PIXCI-EB1 manufactured by EPIX, Inc. is recommended.

Please confirm with us if you are using different grabber.

- PC

Please confirm the recommended requirement of the Camera Link frame grabber you are using.

ARTRAY CO., LTD. Obtained ISO 9001: 2015 2018/9/17

1-17-5 Kouenjikota, Suginami-ku, Tokyo 166-0002 Japan

Tel: +81-3-3389-5488 Fax: +81-3-3389-5486

Email: sales@artray.us URL: www.artray.us

ARTRAY