

Thermal Infrared Camera
ARTCAM-640P2-THERMO
INSTRUCTION BOOKLET

ARTRAY

ARTRAY CO., LTD.

Contents

1.	Attention.....	- 3 -
2.	Introduction	- 6 -
3.	Main Features.....	- 6 -
4.	The Product.....	- 7 -
5.	Connections.....	- 7 -
5.1.	How to Connect a Camera	- 7 -
6.	Specifications.....	- 8 -
6.1.	Detailed specifications	- 8 -
6.2.	Dimensional outline	- 9 -
7.	Systems Requirements.....	- 10 -
7.1.	Recommended Specifications	- 10 -

1. Attention

■About this manual

1. Before using the camera, please read this manual thoroughly.
2. Please keep this manual reachable and always refer to the contents when needed.
3. Please contact us if the manual is lost or damaged. We will provide a replacement.
4. We cannot guarantee the safety of improper uses of the camera.
5. For your safety, please follow the directions of this manual.
6. All contents are subject to change.
7. Images in this manual may have been simplified to be easier comprehended.
8. Please contact us if you find any unclear points or mistakes in this manual.
9. Quoting, copying or altering some or all parts of the manual without our permission is prohibited.
10. We are not responsible for any lost or damages on your profits due to the use of our products.
11. Please understand that our oversea branches do not provide maintenance or repair services.

■About the Icons

To keep the safety of the user, other people and their properties, please pay attention to the following icons.



Warning

If the user fails to follow the instruction, serious injury or death may occur.



Caution

If the user fails to follow the instruction, physical injury on human or damages on hardware may occur.

■ For Safe Use



Warning

- In following circumstances, please stop using the product and turn off the power immediately to prevent the risks of fires and electric shocks. If the product is defective, please contact us for repair or exchange. For your safety, please do not disassemble, modify or repair the camera on your own. Please stop using the product and turn off the power immediately when:
 - The product becomes smoky or gets extremely hot on the surface, or makes unusual smells or sounds.
 - Foreign material or water gets into the product.
 - The product falls and becomes damaged.
- Do not place the product on unstable surfaces. The product may be fallen and people may get hurt.



Caution

- Do not expose the product to steam or fumes to avoid electric shocks and fires.
- Do not leave the product in high temperature places such as inside of vehicles or under direct sunlight. High temperature may cause damages to the camera, or even cause fires.
- Do not cover the product with cloth or other materials. The product may get extremely hot and the heat may cause deformations on the parts or even cause fires.
- Please avoid dropping or shocking the product as the product may be damaged.
- Do not touch the cable with a wet hand. Such action may cause electric shocks.
- Please avoid continuously contacting the surface of the camera to your skin when the camera is being used. The surface temperature of the camera may cause burns.

■ Other Notices

- Please do not use the camera under strong lights such as sun light for a long period. Also please do not expose the camera under strong lights even when the product is not being used because the sensor might be damaged.

Maintenance

- Wipe the dirt on surface with soft cloth or tissue paper. Do not use alcohol, thinner or benzene to avoid damaging the surface paints.

Electro Magnetic Interference

- The camera may interfere with electronic devices such as TV and radio. Please do not place the camera next to such equipment.

■ Export Control

This product is a List Control item subject to the Foreign Exchange and Foreign Trade Act and its relevant legislations No.1 10 (2) and (4). To export this product from Japan, obtaining export licenses from the Ministry of Economy, Trade and Industry is required. It is also necessary for our company to manage the information of users and the purposes of use. If the end users or purposes of use change after the purchase and thus cause the need to apply export licenses from Ministry of Economy, Trade and Industry, please contact the sales representative in advance.

About the Japanese Security Export Controls, please refer to the webpage for Security Export Control Policy, the Ministry of Economy, Trade and Industry:

www.meti.go.jp/policy/anpo/englishpage.html

The above is based on the enforcement laws and regulations at the time of issuance of this document. Please be sure to check the latest laws and regulations before actually exporting this product.

■ Guarantee

To save the environment, we do not issue warranty in printed format. Instead, all records of the warranty periods, delivery dates and the customer information are well kept in our system.

For more details, please refer to the sites below:

Hardware Warranty: www.artray.us/download/artray_warranty.pdf

■ Dispose

To dispose this product, please return the camera to us. If you decide to dispose the camera without returning it us, please follow related regulations and have the camera disposed as an industrial waste. Please always keep records of the dispose, and make sure the disposed camera cannot be accessed or used by any 3rd party.

■ Limited Responsibility

We do not guarantee the functions of this product or the descriptions on this manual to be completely adapted to the users' end applications or marketing purposes. We are also not held responsible for any direct or indirect damages caused by our products under any circumstances.

Please do not use this product on applications that require high reliability. This product is not manufactured to be used as medical, nuclear, aerospace, transportation equipment or equipment that is highly related to human safety. We are not held responsible for any damages on the users' property, equipment or personal safety caused by this product.

2. Introduction

ARTCAM-640P2-THERMO is a thermal infrared camera, which adopts microbolometer and sensitive to FIR wavelength between 8~14 μ m.

The resolution of this camera is 640 x 480 pixels.

Adopting USB2.0 interface, thus enables direct data transfer to PC without a capture board or a host adapter card.

Specially designed Viewer software ART-THERMO included, which makes it easier to acquire thermal images.

3. Main Features

- FIR (Far infrared) sensitivity

Adopting uncooled microbolometer as an infrared detector, sensitive to standard FIR wavelength (8 ~14 μ m).

- High Resolution

Possible to output images with a resolution up to 640 x 480 pixels. The data (14 bits) obtained from the infrared detector can be transfer to a PC without compressing.

- USB2.0 Interface

Adopting USB2.0 interface, thus enables direct data transfer to PC without a capture board or a host adapter card.

- NTSC Output (Option)

Adopting analog output terminal NTSC, so the image can be delivered to analog monitors directly.

- Viewer software ART-THERMO is attached

Viewer Software ART-THERMO, which is designed especially for Thermal Infrared Cameras and compatible with Windows 7/8/10, is attached as standard.

Functions such as previewing, various settings, still/ moving image savings, graph creating and alarming are included.

4. The Product

- 1) Camera
- 2) 3m USB2.0 cable
- 3) Viewer Software (including temperature calibration data)

< Option >

- 1) Germanium lens (Focal length : 8.5mm / 19mm)

5. Connections

5.1. How to Connect a Camera

- USB Output

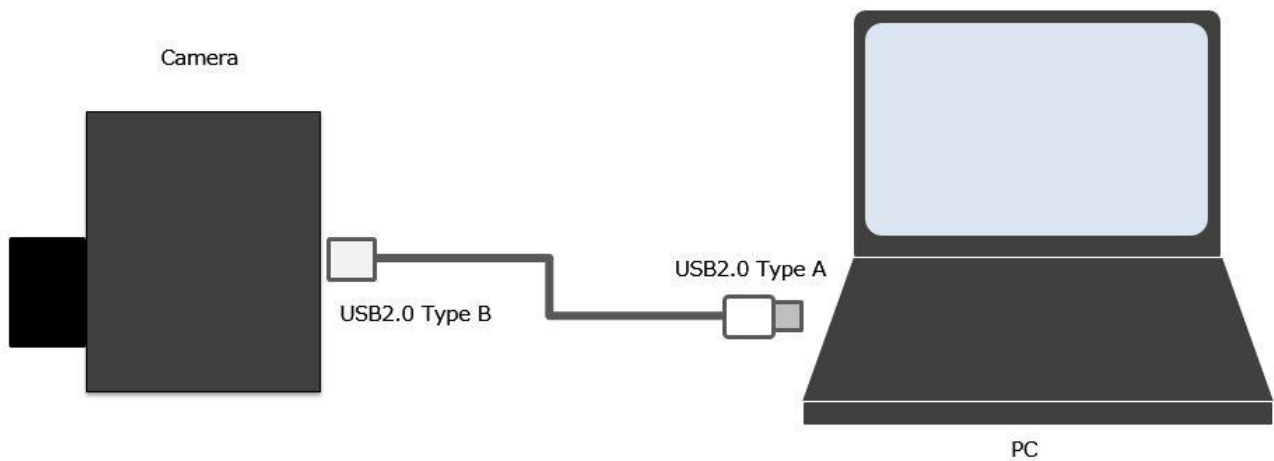

- NTSC Output (Option)

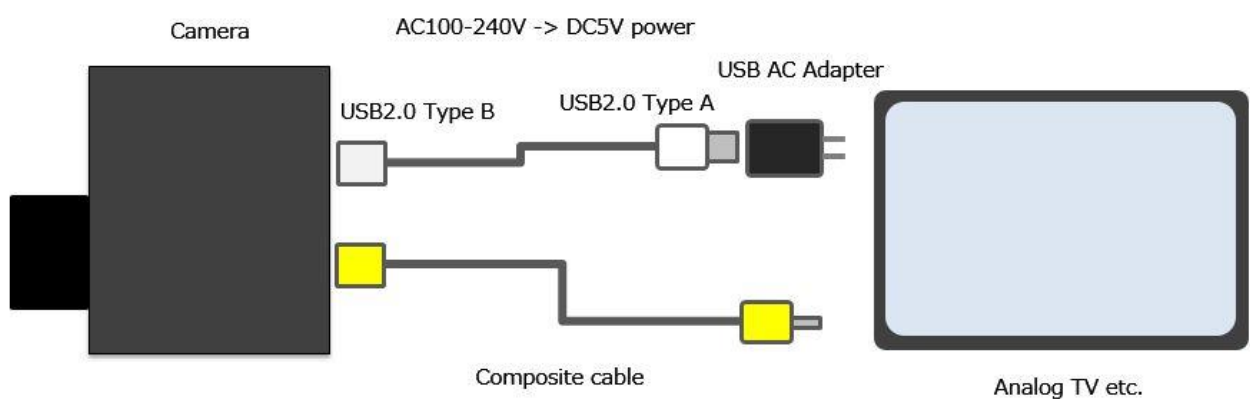

6. Specifications

6.1. Detailed specifications

Items	
Sensor Type	Uncooled Micro bolometer
Detected Wavelength	8~14 μ m
Interface	USB2.0, NTSC (Option)
Resolution	640(H) X 480(V)
Pixel Pitch	17 μ m
Output Bits	14bit
Frame Rate	30fps
Operability	> 99.5 %
Electronic shutter	150 μ s
Temperature Measurement Range	0° C~120° C
Temperature Resolution	< 75mK
Thermal Time Constant	12msec typ.
Synchronization Method	Internal Synchronization
Lens Mount	M25 X P0.5
Compatible lenses and FOV	Focal length : 8.5mm FOV : 73.0° (H) X 54.0° (V) Focal length : 19mm FOV : 32.0° (H) X 24.0° (V) * Lenses are optional. Please choose the lens when you purchase.
Power Supply	5.0V (\pm 0.5V) USB BUS Power
Power Consumption	< Approx. 2.5 W (ambient temperature 25° C)
Startup Time	\leq 5s
Operation Temperature / Humidity	0 ~ 35° C / 10 ~ 80% (Non-water vapor condensation state)
Recommended temperature for measurement	TBD
Dimension	46.6(W) X 51(H) X 51.5(D)mm ※Lens and tripod mount not included
Weight	Approx.140g ※Lens and tripod mount not included

6.2. Dimensional outline

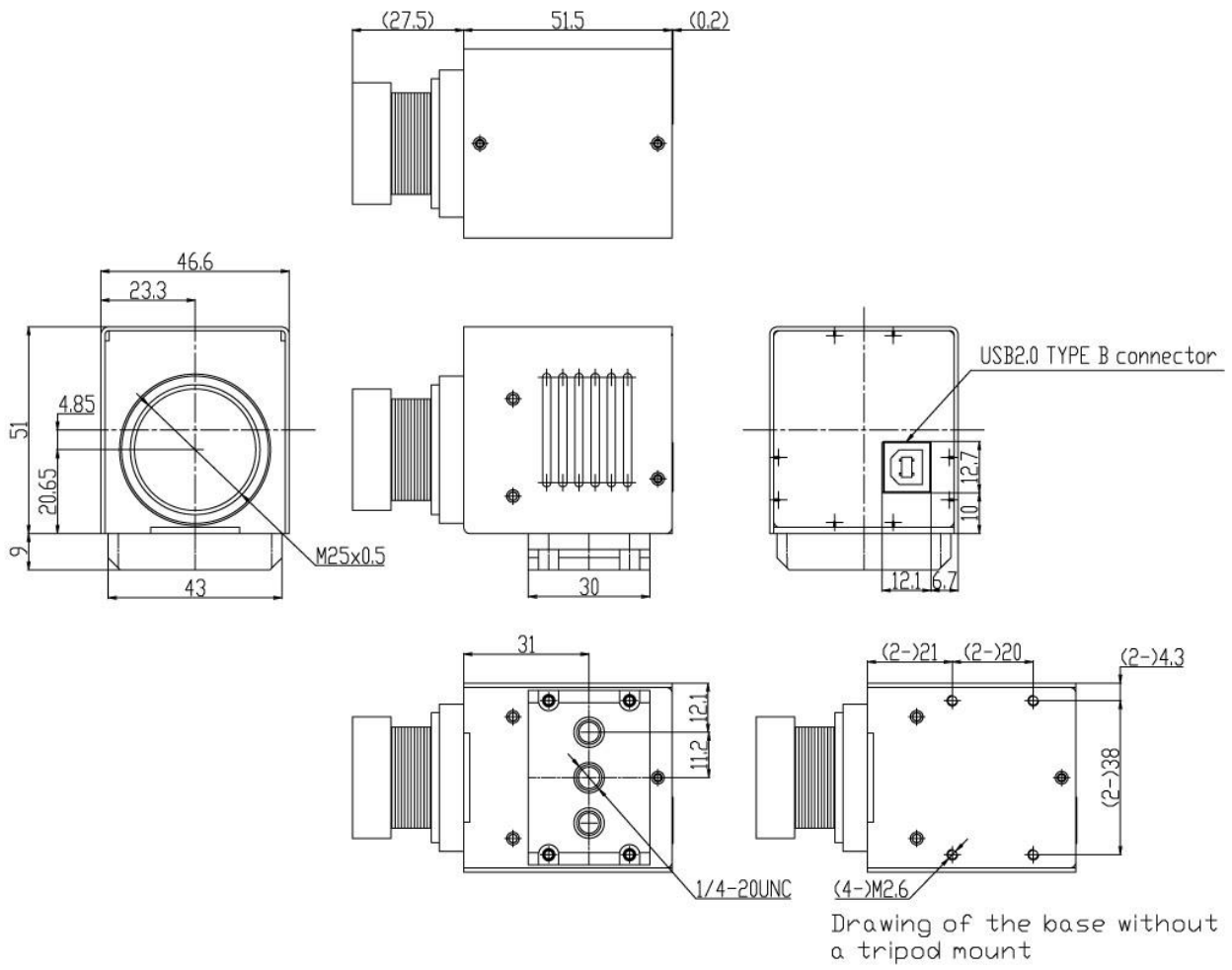

7. Systems Requirements

7.1. Recommended Specifications

- Host Controller

This camera is applicable to USB 2.0.

- CPU

The driver of this camera is applicable to computer architecture “x86” or “amd64”.

The specification of CPU effects directly the imaging process speed, therefore it is highly recommended to utilize a high-end CPU if possible.

- Memory

In the viewer software, there is a data buffer which can store 4 to 8 frames.

Therefore, it is necessary to keep spare space at least for 8 frames in the memory.

(For example, when using 1.3MP color camera, $1280 \times 1024 \times 3 \times 8$ [byte] = 30[MB] is necessary.)

It is highly recommended to keep enough memory space especially when using high resolution camera.

- OS

This camera is applicable only to the architecture of Windows NT (32bit/64bit).

Standard functions are confirmed with OS after Windows 7.

In addition, it is recommended to use Windows 10.



Caution

■ Please refer the restrictions below when you use ARTCAM series.

(1) Recommended System Requirements

If the system specifications do not meet the requirements recommended above, it may be difficult to run at the maximum frame rate.

(2) Connection of Multiple USB Devices

When connecting multiple USB devices to one USB host controller, some USB device may fail to function stably depending on the specifications of the host controller.

(Problem of power supply, data transfer bandwidth, etc.)

To avoid power supply problem, it is recommended to use powered USB hub.

(3) USB2.0 Cable Extension

We cannot guarantee the functionality of the USB2.0 camera if the user adopts USB2.0 extension cables or repeaters which are not confirmed by us. With the extension cables or repeaters, the bandwidth of transfer may differ, and thus caused malfunctions such as a low frame rate or recognition failure on the camera.

What may cause the problem is that the regulation of the power lines becomes not enough, and so causes impedance mismatch on data signals.

*For the recommended extension cable, please contact our sales department.

(TEL: +81-3389-5488)

ARTRAY CO., LTD. Obtained ISO 9001: 2015 2018/9/17

1-17-5 Kouenjikota, Suginami-ku, Tokyo 166-0002 Japan

Tel: +81-3-3389-5488

Fax: +81-3-3389-5486

Email: sales@artray.us

URL: www.artray.us

ARTRAY