

December 17, 2020

Ver1.00

USB3.0 InGaAs NIR CAMERA  
ARTCAM-990SWIR  
INSTRUCTION BOOKLET

**ARTRAY**  
ARTRAY CO., LTD.

# Contents

1. Attention .....	- 3 -
2. Introduction.....	- 6 -
3. Main Features .....	- 6 -
4. The Product .....	- 6 -
5. Connect the Camera .....	- 7 -
5.1. How to Connect a Camera.....	- 7 -
6. Specifications.....	- 8 -
6.1. Camera Specification .....	- 8 -
6.1.1. Analog / Digital Gain Settings.....	- 9 -
6.1.2. Dimensional Outline.....	- 10 -
6.1.3. Sensor Package Information .....	- 11 -
6.1.4. Sensor Position and the Light Receiving Surface.....	- 12 -
6.1.5. Field of Vision: Lens versus Sensor (For Reference Only) .....	- 12 -
6.2. Sensor Specification (Based on sensor datasheet from the manufacturer) .....	- 13 -
6.2.1. Sensor Specification .....	- 13 -
6.2.2. Spectral Sensitivity Characteristics .....	- 13 -
6.3. Camera Function.....	- 14 -
6.3.1. Eternal Trigger Function(Optional).....	- 14 -
6.3.2. Trigger Timing .....	- 15 -
7. System Requirements .....	- 16 -
7.1. Recommended System Requirements .....	- 16 -

# 1. Attention

## ■ About this manual

1. Before using the camera, please read this manual thoroughly.
2. Please keep this manual reachable and always refer to the contents when needed.
3. Please contact us if the manual is lost or damaged. We will provide a replacement.
4. We cannot guarantee the safety of improper uses of the camera.
5. For your safety, please follow the directions of this manual.
6. All contents are subject to change.
7. Images in this manual may have been simplified to be easier comprehended.
8. Please contact us if you find any unclear points or mistakes in this manual.
9. Quoting, copying or altering some or all parts of the manual without our permission is prohibited.
10. We are not responsible for any lost or damages on your profits due to the use of our products.
11. Please understand that our oversea branches do not provide maintenance or repair services.

## ■ About the Icons

To keep the safety of the user, other people and their properties, please pay attention to the following icons.



Warning

If the user fails to follow the instruction, serious injury or death may occur.



Caution

If the user fails to follow the instruction, physical injury on human or damages on hardware may occur.

■ For Safe Use



## Warning

● In following circumstances, please stop using the product and turn off the power immediately to prevent the risks of fires and electric shocks. If the product is defective, please contact us for repair or exchange. For your safety, please do not disassemble, modify or repair the camera on your own.

Please stop using the product and turn off the power immediately when:

- The product becomes smoky or gets extremely hot on the surface, or makes unusual smells or sounds.
  - Foreign material or water gets into the product.
  - The product falls and becomes damaged.
- Do not place the product on unstable surfaces. The product may be fallen and people may get hurt.



## Caution

- Do not expose the product to steam or fumes to avoid electric shocks and fires.
- Do not leave the product in high temperature places such as inside of vehicles or under direct sunlight. High temperature may cause damages to the camera, or even cause fires.
- Do not cover the product with cloth or other materials. The product may get extremely hot and the heat may cause deformations on the parts or even cause fires.
- Please avoid dropping or shocking the product as the product may be damaged.
- Do not touch the cable with a wet hand. Such action may cause electric shocks.
- Please avoid continuously contacting the surface of the camera to your skin when the camera is being used. The surface temperature of the camera may cause burns.

■ Other Notices

- Please do not use the camera under strong lights such as sun light for a long period. Also, please do not expose the camera under strong lights even when the product is not being used because the sensor might be damaged.

#### ■ Maintenance

- Wipe the dirt on surface with soft cloth or tissue paper. Do not use alcohol, thinner or benzene to avoid damaging the surface paints.

#### ■ Export Control

This product is a List Control item subject to the Foreign Exchange and Foreign Trade Act and its relevant legislations No.1 10 (2) and (4). To export this product from Japan, obtaining export licenses from the Ministry of Economy, Trade and Industry is required. It is also necessary for our company to manage the information of users and the purposes of use. If the end users or purposes of use change after the purchase and thus cause the need to apply export licenses from Ministry of Economy, Trade and Industry, please contact the sales representative in advance.

#### ■ Guarantee

To save the environment, we do not issue warranty in printed format. Instead, all records of the warranty periods, delivery dates and the customer information are well kept in our system.

For more details, please refer to the sites below:

Hardware Warranty: [http://www.artray.us/download/artray\\_warranty.pdf](http://www.artray.us/download/artray_warranty.pdf)

#### ■ Dispose

To dispose this product, please return the camera to us. If you decide to dispose the camera without returning it us, please follow related regulations and have the camera disposed as an industrial waste. Please always keep records of the dispose, and make sure the disposed camera cannot be accessed or used by any 3rd party.

#### ■ Limited Responsibility

We do not guarantee the functions of this product or the descriptions on this manual to be completely adapted to the users' end applications or marketing purposes. We are also not held responsible for any direct or indirect damages caused by our products under any circumstances.

Please do not use this product on applications that require high reliability. This product is not manufactured to be used as medical, nuclear, aerospace, transportation equipment or equipment that is highly related to human safety. We are not held responsible for any damages on the users' property, equipment or personal safety caused by this product.

## 2. Introduction

This manual is to identify the specification of ARTCAM-990SWIR, NIR camera adopting InGaAs (Indium gallium arsenide) sensor with USB3.0 interface.

## 3. Main Features

- NIR Detection with High Sensitivity

The InGaAs sensor can detect radiation invisible to human eyes and CCD/CMOS cameras in the wavelength range between 400 nm to 1700 nm band.

- High Resolution, High Frame Rate

ARTCAM-990SWIR uses a higher resolution sensor of 1280 x 1024 pixel and delivers image at 70 fps.

- USB3.0 Interface

This camera adopts USB3.0 interface, so the data can be delivered to PC directly. No capture card is needed.

## 4. The Product

- 1) Camera
- 2) USB3.0 Cable Type A-micro B connector cable, 3m approx.
- 3) Special viewer software/Device Driver CD

<Options>

- 1) NIR Lenses (C Mount Lens)

## 5. Connect the Camera

### 5.1. How to Connect a Camera

Please connect the camera and the PC by using the attached USB3.0 cable.

Camera's power is supplied from USB Bus Power.

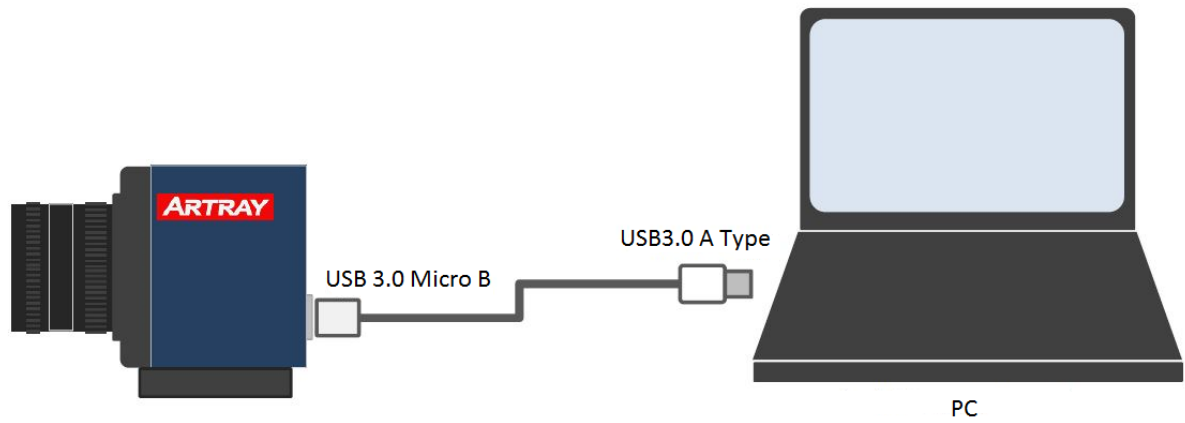

## 6. Specifications

### 6.1. Camera Specification

MODEL	ARTCAM-990SWIR
Sensor Type	1.3MP InGaAs Image Sensor
Interface	USB3.0 Bulk Transfer
Output Bit Depth	12bit
Frame Rate	72fps (12bit)
Shutter Speed	20.3μsec. ~ 2sec.
Synchronization System	Internal Synchronization / External Trigger Synchronization(Optional)
Lens Mount	C Mount
External trigger input (option)	SMA female connector (when option selected) BNC conversion adapter included
Power	DC5V USB BUS Power
Power Consumption	Under Approx.3.2W
Ambient Conditions	Operating Temperature/Humidity: 10~35°C/10~80% (Non-condensing) Storage Temperature/Humidity: 0~60°C /10~95% (Non-condensing)
External Dimensions	50.0(W) x 47.0(H) x 42.7(D)mm ※Lens, Tripod mount and cables not included
Weight	About 110g



### 6.1.1. Analog / Digital Gain Settings

ARTCAM-990SWIR is compatible with analog and digital gain.

Setting value of gain on software can be set from 0 ~ 420, and the gain will change from 0.0dB ~ 42.0dB accordingly. Gain can be calculated by the following formula:

$$\text{Gain[dB]} = \text{value} / 10.0[\text{dB}]$$

Digital gain will activate when setting value of gain > 180.

The graph below shows the relationship between setting value of gain and its magnification[dB].

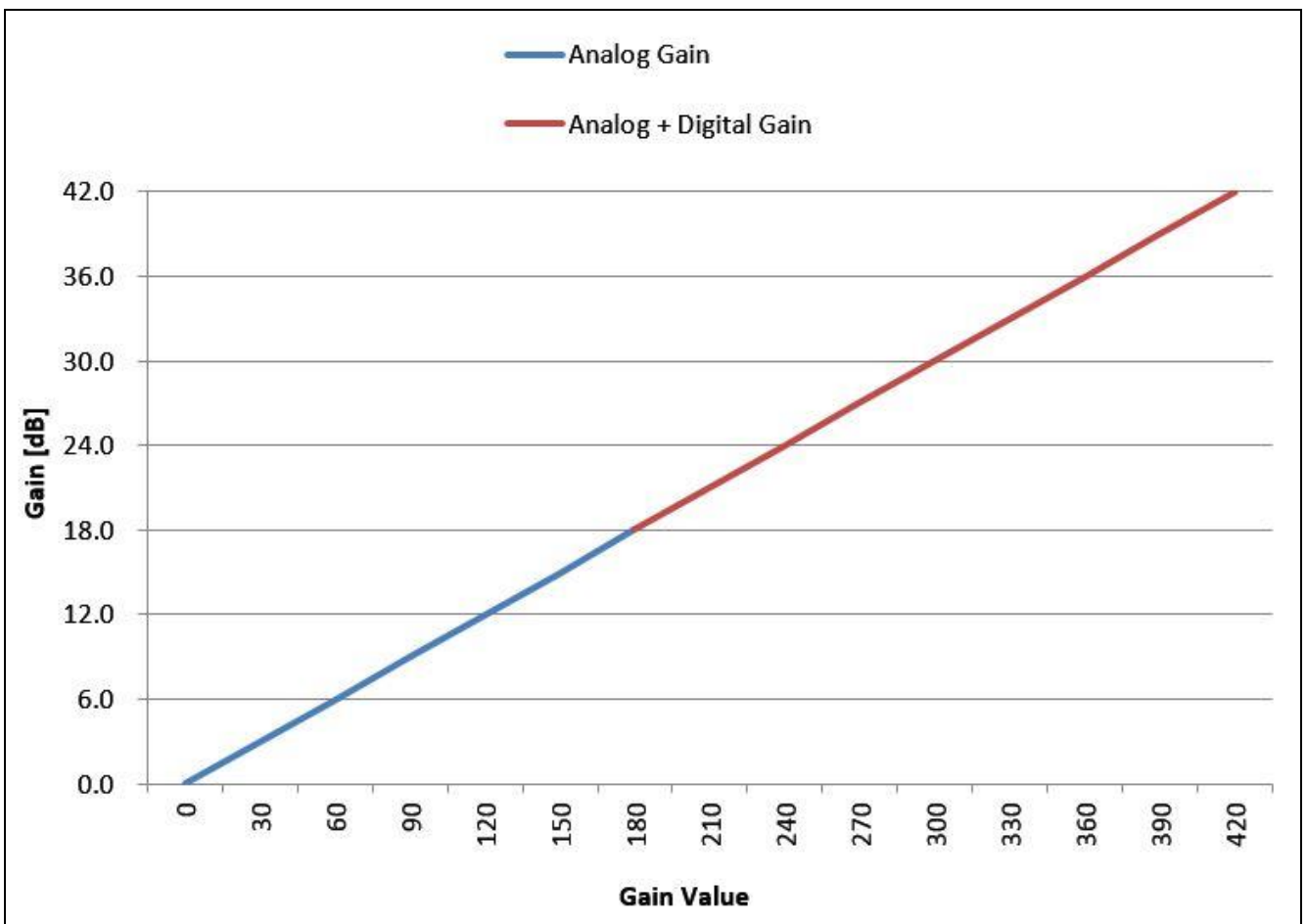

## 6.1.2. Dimensional Outline

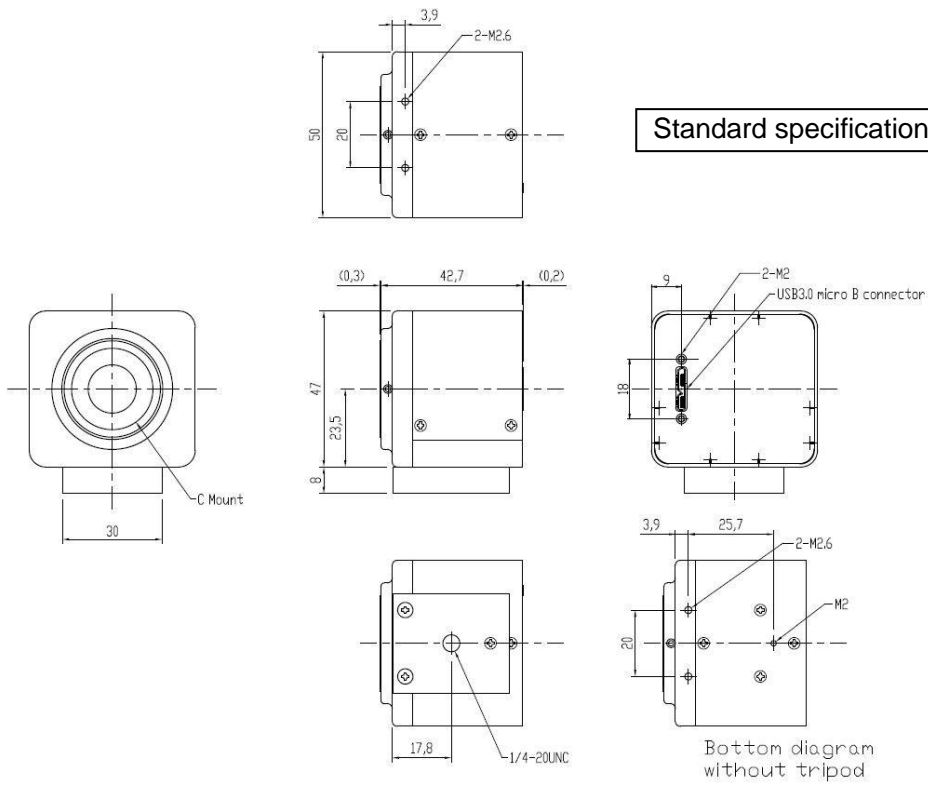

Drawing of the base without a tripod mount

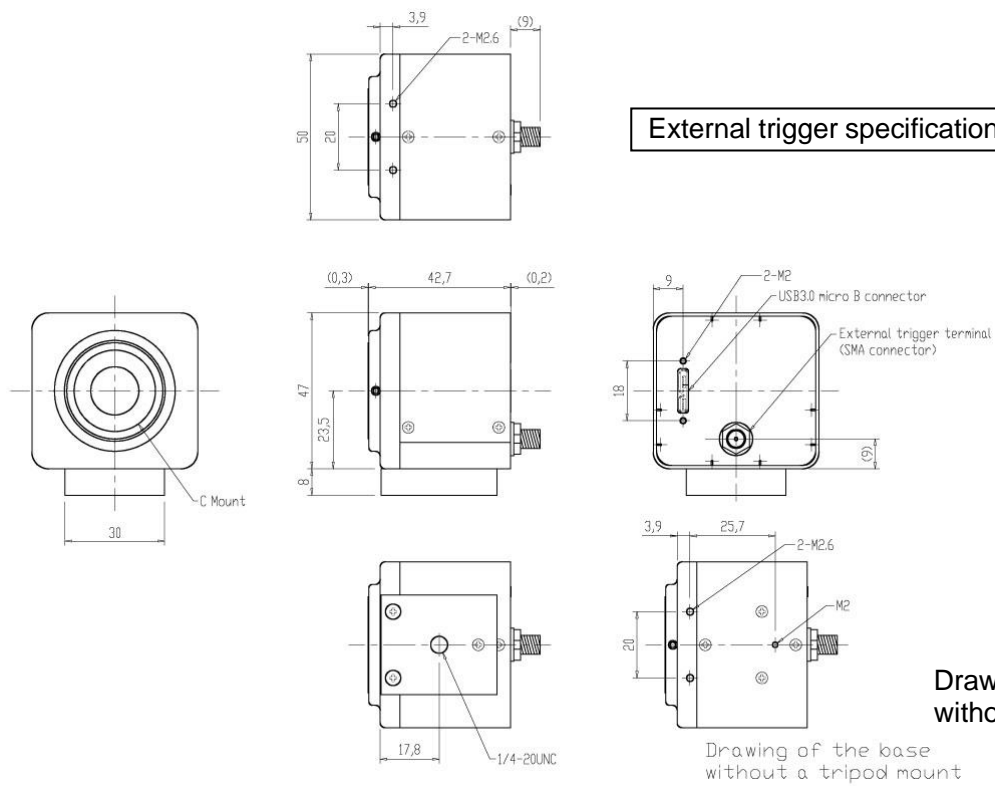

Drawing of the base without a tripod mount

※The dimension might be changed.

### 6.1.3. Sensor Package Information

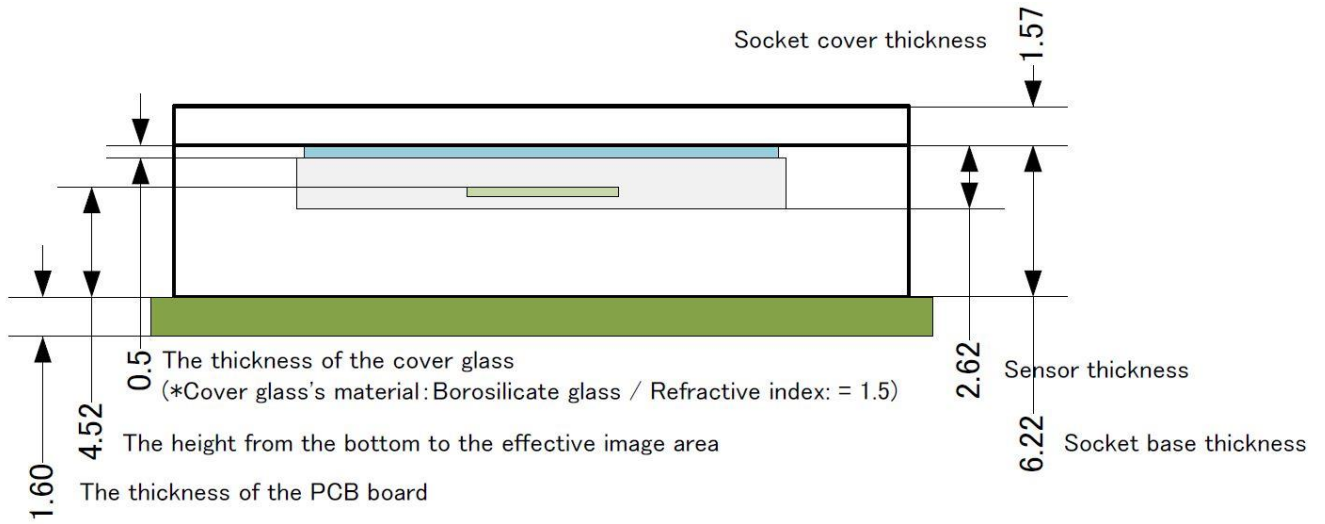

**6.1.4. Sensor Position and the Light Receiving Surface**

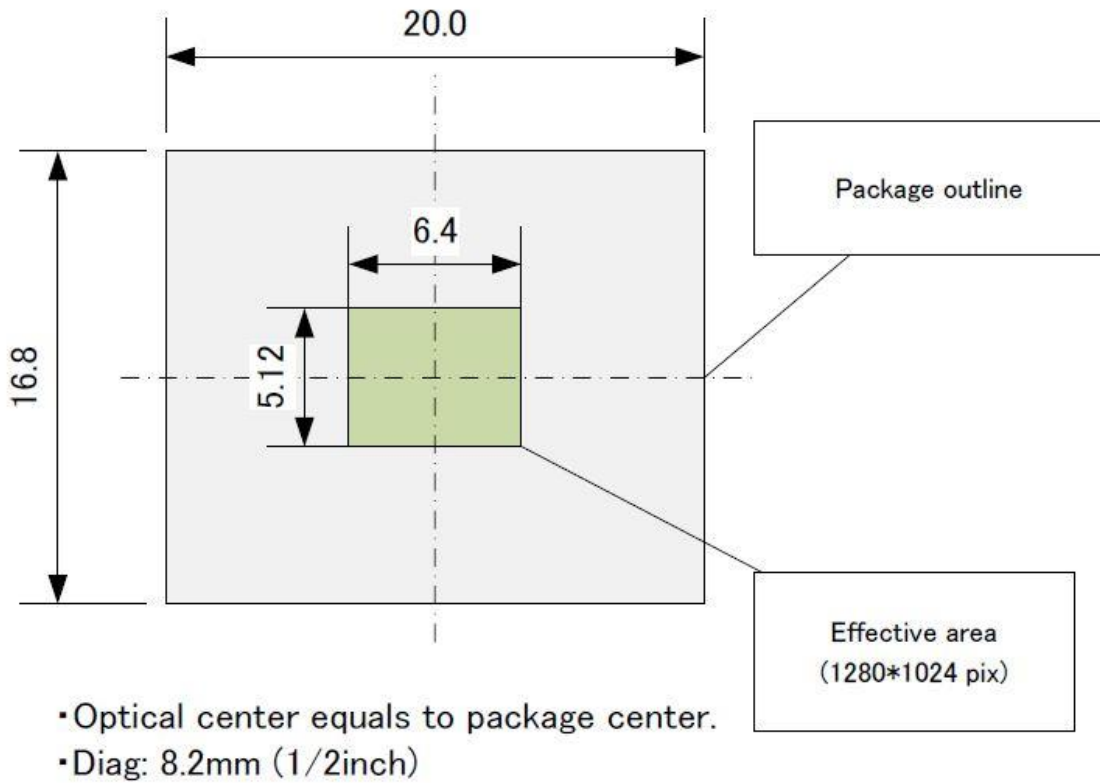

$H = 5[\mu\text{m}] * 1280 = 6400 [\mu\text{m}]$

$V = 5[\mu\text{m}] * 1024 = 5120 [\mu\text{m}]$

**6.1.5. Field of Vision: Lens versus Sensor (For Reference Only)**

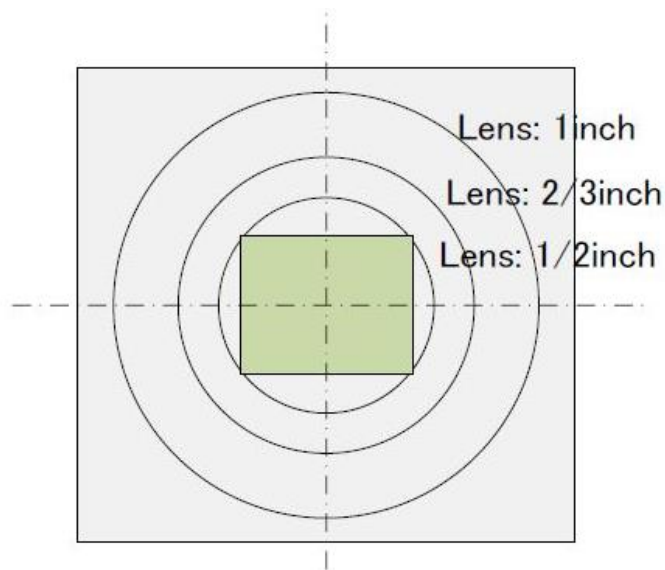

※The ratios of sensor size (diagonal) to lens size in the above illustrations are as follows:

1/2 inch =  $\varnothing$ 8mm, 2/3 inch =  $\varnothing$ 11mm, 1 inch = 15.8mm.

Please note that the actual field of view varies depending on different lens.

## 6.2. Sensor Specification (Based on sensor datasheet from the manufacturer)

### 6.2.1. Sensor Specification

Sensor Model	SONY IMX990-AABJ-C
Actual Pixel Array	1296(H) × 1032(V)
Effective Pixel Array	1280(H) × 1024(V)
Pixel Pitch	5[ $\mu\text{m}$ ] × 5[ $\mu\text{m}$ ]
Image Size	6.4[mm] × 5.12[mm] (Diagonal length: 8.2[mm], 1/2")
Spectral Range	400nm~1700nm
Shutter type	Global Shutter
S/N Ratio	51dB (for reference only)
A/D Resolution	12bit

### 6.2.2. Spectral Sensitivity Characteristics

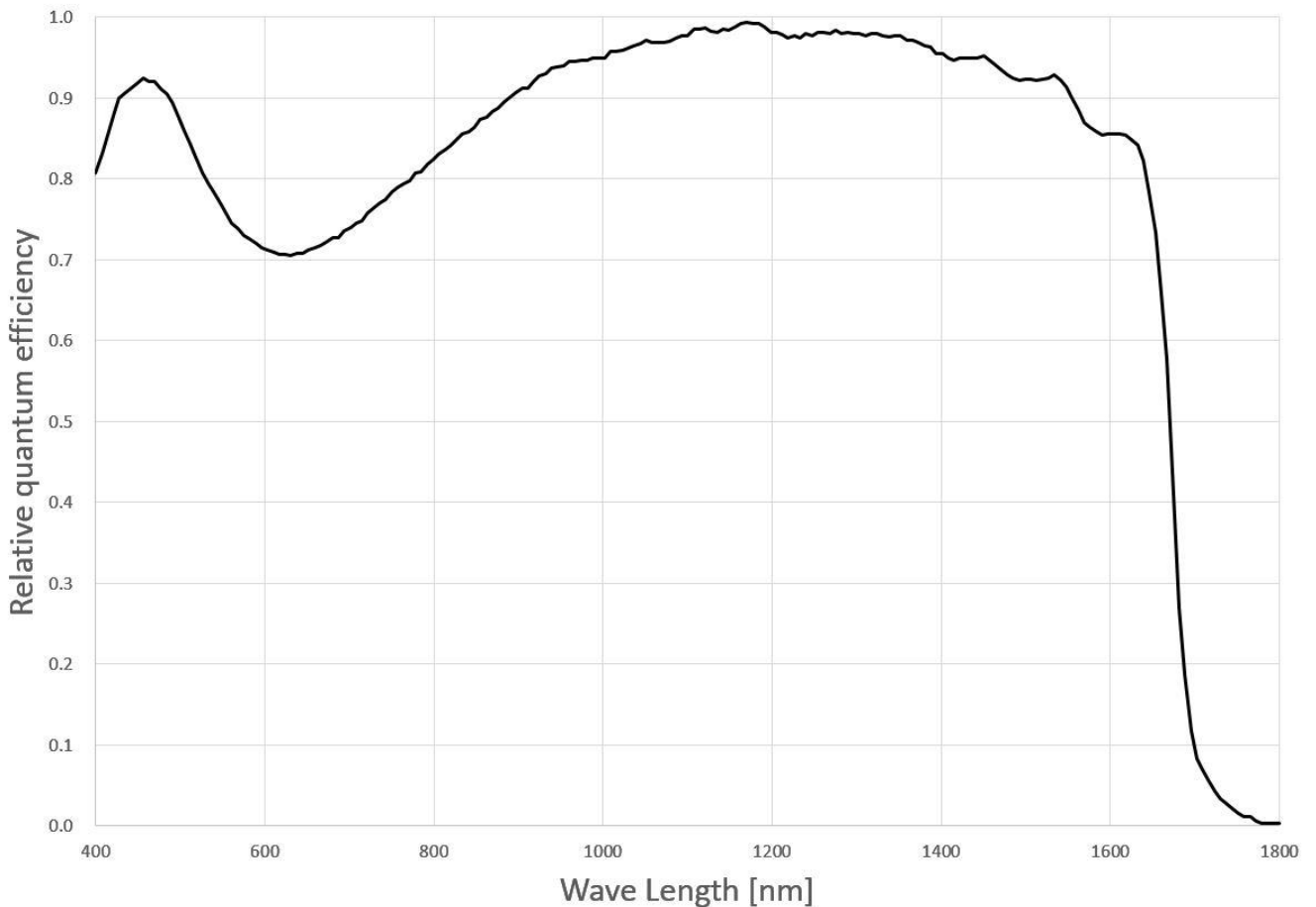

### 6.3. Camera Function

The functions of the camera are as follows.

NO	ITEM	RANGE	DEFAULT VALUE	REMARKS
1	Shutter Speed	20.3[ $\mu$ s]~2[s]	1[ms]	
2	Gain (Analog/Digital)	0~420 (0~42[dB])	0 (0[dB])	Gain [dB] = Value/10
3	ROI, Sub-sampling (1/2)	ON/OFF	OFF	ROI: Vertical only (Horizontal only available on software) Sub-sampling: 1/2
4	Trigger	ON/OFF	OFF	
5	Mirroring	ON/OFF	OFF	Vertical and Horizontal

#### 6.3.1. External Trigger Function(Optional)

This camera has an external trigger electronic circuit, which is insulated by a photocoupler, and thus enables synchronized shooting by the input signal received from the external circuit.

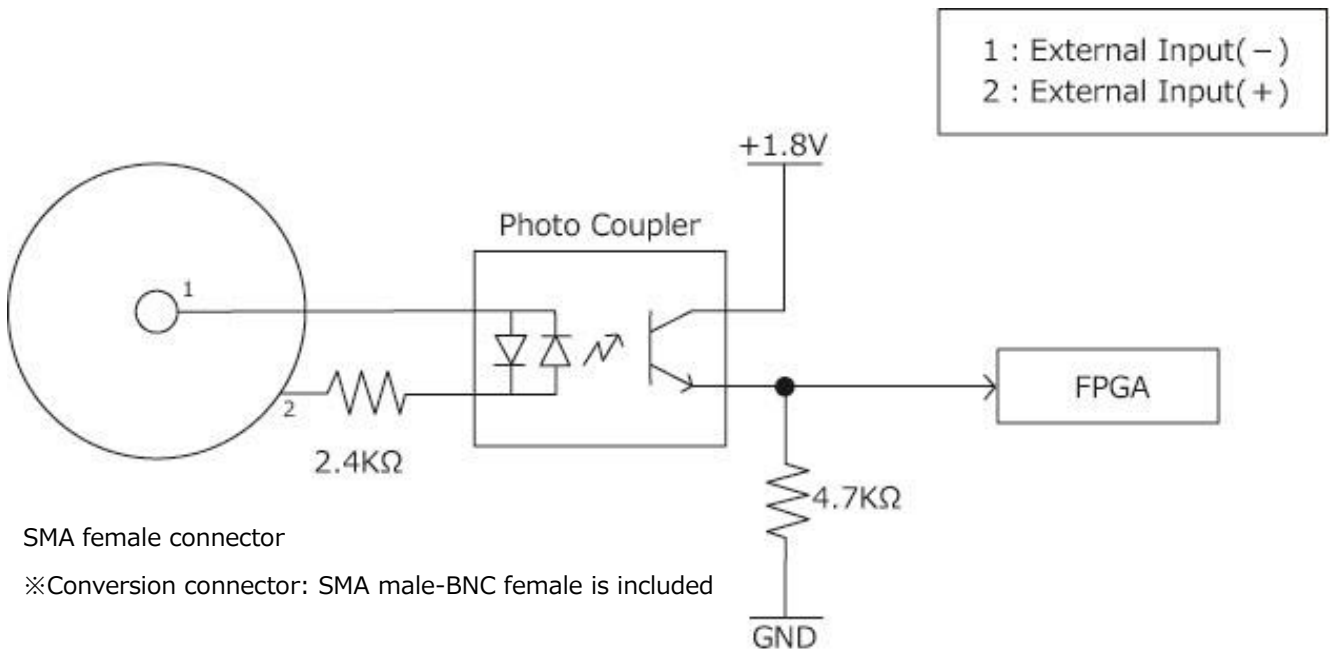

※The connector is subject to change.

### 6.3.2. Trigger Timing

Details of Trigger Timing

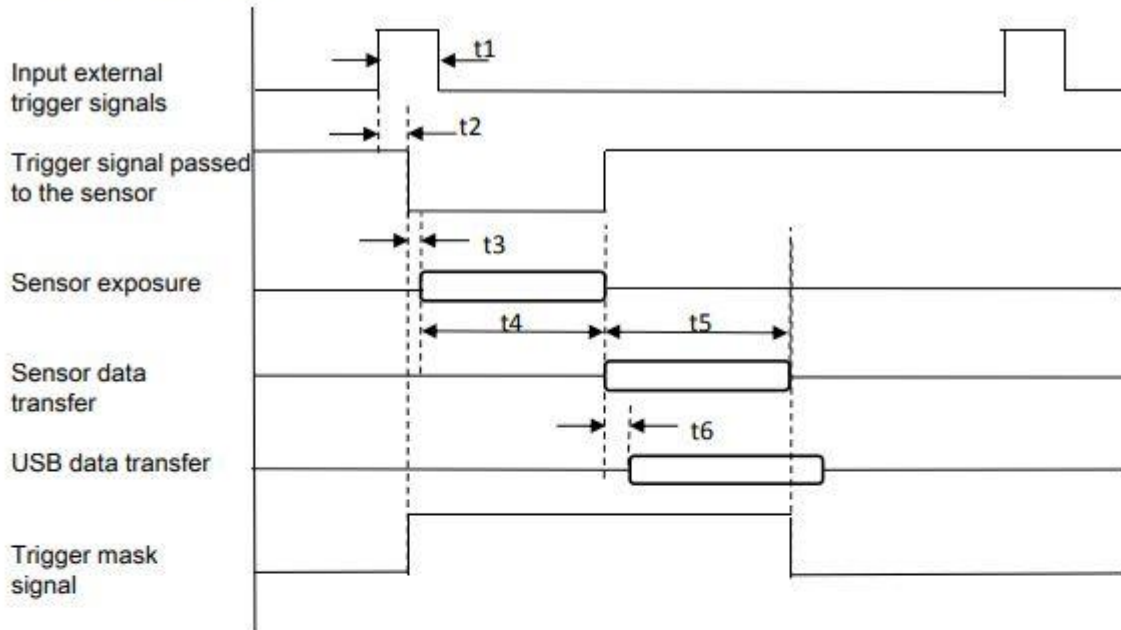

Item No.	Items	Required Time
t1	Effective Trigger Input Pulse	>10 $\mu$ sec.
t2	From the rise of the external trigger input to the fall of the trigger signal passed to the sensor (Delay due to photocoupler)	<1 $\mu$ sec.
t3	From the fall of the trigger signal passed to the sensor to the start of exposure	Max 0.13us
t4	Exposure Time	Exposure Time = The setting value of the Shutter Speed * 1H
t5	Time required for data transfer (from the sensor to the FPGA)	(9+Effective Vertical Pixels) * 1Hperiod
t6	Time required for the transfer (from the FPGA to USB)	Depending on the PC specification and software

# 7. System Requirements

## 7.1. Recommended System Requirements

- Host Controller

This camera is applicable to USB 3.0.

Connecting to USB 2.0 host controller may cause low-speed or failure to function properly.

- CPU

The driver of this camera is applicable to computer architecture "x86" or "amd64".

The specification of CPU effects directly the imaging process speed, therefore it is highly recommended to utilize a high-end CPU if possible.

- Memory

In the viewer software, there is a data buffer which can store 4 to 8 frames.

Therefore, it is necessary to keep spare space at least for 8 frames in the memory.

(For example, when using 1.3MP color camera,  $1280 \times 1024 \times 3 \times 8$  [byte] = 30[MB] is necessary.)

It is highly recommended to keep enough memory space especially when using high resolution camera.

- OS

This camera is applicable only to the architecture of Windows NT (32bit/64bit).

Standard functions are confirmed with OS after Windows.

In addition, it is recommended to use Windows 10.



## Caution

- Please refer the restrictions below when you use ARTCAM series.

- (1) Recommended System Requirements

If the system specifications do not meet the requirements recommended above, it may be difficult to run at the maximum frame rate.

- (2) Use of other USB3.0 Hardware

The data on our camera/converter is transferred in bulk mode. For this reason, when using our camera/converter, please avoid using other bulk transferred USB3.0 hardware such as Memory stick, External HDD, External DVD, CDROM etc.

As a solution, we recommend installing a PCI USB host card to the PC and connect external USB hardware to this port only.

- (3) USB3.0 Cable Extension

We cannot guarantee the functionality of the USB3.0 camera if the user adopts USB3.0 extension cables or repeaters which are not confirmed by us. With the extension cables or repeaters, the bandwidth of transfer may differ, and thus caused malfunctions such as a low frame rate or recognition failure on the camera.

What may cause the problem is that the regulation of the power lines becomes not enough, and so causes impedance mismatch on data signals.

\*For the recommended extension cable, please contact our sales department.

(TEL: +81-3389-5488)



ARTRAY Co., LTD. Obtained ISO 9001: 2015 2018/9/17  
1-17-5 Kouenjikita, Suginami-ku, Tokyo 166-0002 Japan  
TEL: +81-3-3389-5488 FAX: +81-3-3389-5486  
Email: sales@artray.us URL: www.artray.us

**ARTRAY**