

Camera Link Connection
InGaAs Camera
ARTCAM-991SWIR-TEC-CL
INSTRUCTION BOOKLET

ARTRAY
ARTRAY CO., LTD.

Contents

1. Attention	- 3 -
2. Introduction	- 6 -
3. Main Features	- 6 -
4. The Product.....	- 6 -
5. Connect the Camera	- 7 -
5.1. How to Connect a Camera.....	- 7 -
5.1.1. When connecting to a desktop PC	- 7 -
5.1.2. When connecting to a notebook PC.....	- 7 -
6. Specifications.....	- 8 -
6.1. Camera Specification	- 8 -
6.1.1. Analog / Digital Gain Settings.....	- 9 -
6.1.2. Shutter speed calculation	- 9 -
6.1.3. Dimensional Outline	- 10 -
6.1.4. Sensor Package Information	- 10 -
6.1.5. Sensor Position and the Light Receiving Surface	- 11 -
6.1.6. Field of Vision: Lens versus Sensor (For Reference Only)	- 11 -
6.2. Spectral Sensitivity Characteristics.....	- 12 -
6.3. External Trigger Function	- 12 -
6.4. Trigger Timing	- 13 -
7. Recommended System Requirements.....	- 14 -

1. Attention

■ About this manual

1. Before using the camera, please read this manual thoroughly.
2. Please keep this manual reachable and always refer to the contents when needed.
3. Please contact us if the manual is lost or damaged. We will provide a replacement.
4. We cannot guarantee the safety of improper uses of the camera.
5. For your safety, please follow the directions of this manual.
6. All contents are subject to change.
7. Images in this manual may have been simplified to be easier comprehended.
8. Please contact us if you find any unclear points or mistakes in this manual.
9. Quoting, copying or altering some or all parts of the manual without our permission is prohibited.
10. We are not responsible for any lost or damages on your profits due to the use of our products.
11. Please understand that our oversea branches do not provide maintenance or repair services.

■ About the Icons

To keep the safety of the user, other people and their properties, please pay attention to the following icons.



Warning

If the user fails to follow the instruction, serious injury or death may occur.



Caution

If the user fails to follow the instruction, physical injury on human or damages on hardware may occur.

■ For Safe Use



Warning

● In following circumstances, please stop using the product and turn off the power immediately to prevent the risks of fires and electric shocks. If the product is defective, please contact us for repair or exchange. For your safety, please do not disassemble, modify or repair the camera on your own.

Please stop using the product and turn off the power immediately when:

- The product becomes smoky or gets extremely hot on the surface, or makes unusual smells or sounds.
- Foreign material or water gets into the product.
- The product falls and becomes damaged.

● Do not place the product on unstable surfaces. The product may be fallen and people may get hurt.



Caution

● Do not expose the product to steam or fumes to avoid electric shocks and fires.

● Do not leave the product in high temperature places such as inside of vehicles or under direct sunlight. High temperature may cause damages to the camera, or even cause fires.

● Do not cover the product with cloth or other materials. The product may get extremely hot and the heat may cause deformations on the parts or even cause fires.

● Please avoid dropping or shocking the product as the product may be damaged.

● Do not touch the cable with a wet hand. Such action may cause electric shocks.

● Please avoid continuously contacting the surface of the camera to your skin when the camera is being used. The surface temperature of the camera may cause burns.

■ Other Notices

● Please do not use the camera under strong lights such as sun light or laser light for a long period. Also, please do not expose the camera under strong lights even when the product is not being used because the sensor might be damaged.

■ Maintenance

● Wipe the dirt on surface with soft cloth or tissue paper. Do not use alcohol, thinner or benzene to avoid damaging the surface paints.

■ Export Control

This product is a List Control item subject to the Foreign Exchange and Foreign Trade Act and its relevant legislations No.1 10 (2) and (4). To export this product from Japan, obtaining export licenses from the Ministry of Economy, Trade and Industry is required. It is also necessary for our company to manage the information of users and the purposes of use. If the end users or purposes of use change after the purchase and thus cause the need to apply export licenses from Ministry of Economy, Trade and Industry, please contact the sales representative in advance.

■ Guarantee

To save the environment, we do not issue warranty in printed format. Instead, all records of the warranty periods, delivery dates and the customer information are well kept in our system.

For more details, please refer to the sites below:

Hardware Warranty: http://www.artray.us/download/artray_warranty.pdf

■ Dispose

To dispose this product, please return the camera to us. If you decide to dispose the camera without returning it us, please follow related regulations and have the camera disposed as an industrial waste. Please always keep records of the dispose, and make sure the disposed camera cannot be accessed or used by any 3rd party.

■ Limited Responsibility

We do not guarantee the functions of this product or the descriptions on this manual to be completely adapted to the users' end applications or marketing purposes. We are also not held responsible for any direct or indirect damages caused by our products under any circumstances.

Please do not use this product on applications that require high reliability. This product is not manufactured to be used as medical, nuclear, aerospace, transportation equipment or equipment that is highly related to human safety. We are not held responsible for any damages on the users' property, equipment or personal safety caused by this product.

2. Introduction

This manual is to identify the specification of ARTCAM-991SWIR-TEC-CL, NIR camera adopting InGaAs (Indium gallium arsenide) sensor with Camera Link interface.

3. Main Features

●NIR Detection with High Sensitivity

The InGaAs sensor can detect radiation invisible to human eyes and CCD/CMOS cameras in the wavelength range between 400 nm to 1700 nm band.

●High Resolution, High Frame Rate

ARTCAM-991SWIR-TEC uses a higher resolution sensor of 640×512 pixel and delivers image at 137 fps.

●CameraLink interface

We adopt high reliability Cameralink interface as industrial application.

4. The Product

- 1) Camera
- 2) AC adapter (DC12V)
- 3) Special viewer software/Device Driver CD

<Options>

- 1) NIR Lenses (C Mount Lens)
- 2) Grabber board (manufactured by EPIX, Inc., is recommended.)
- 3) CameraLink Cable

5. Connect the Camera

5.1. How to Connect a Camera

5.1.1. When connecting to a desktop PC

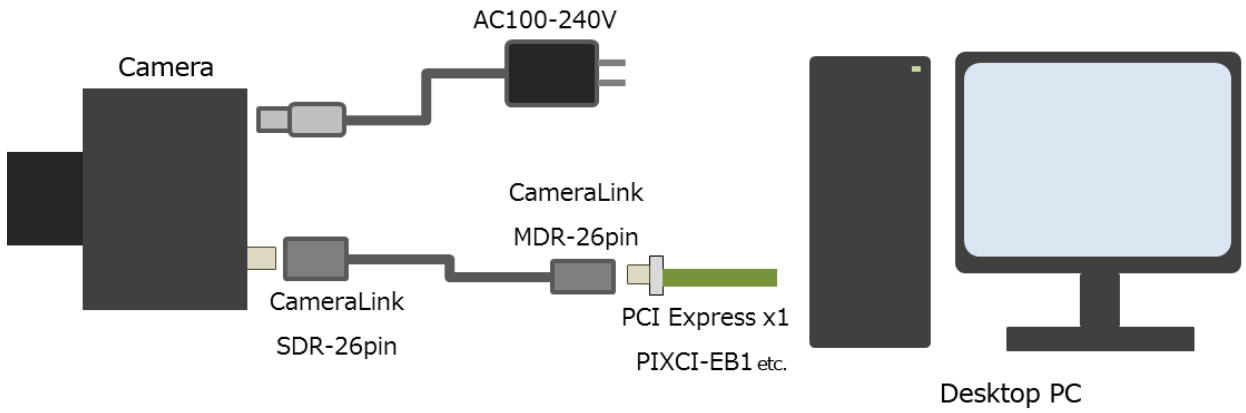

5.1.2. When connecting to a notebook PC

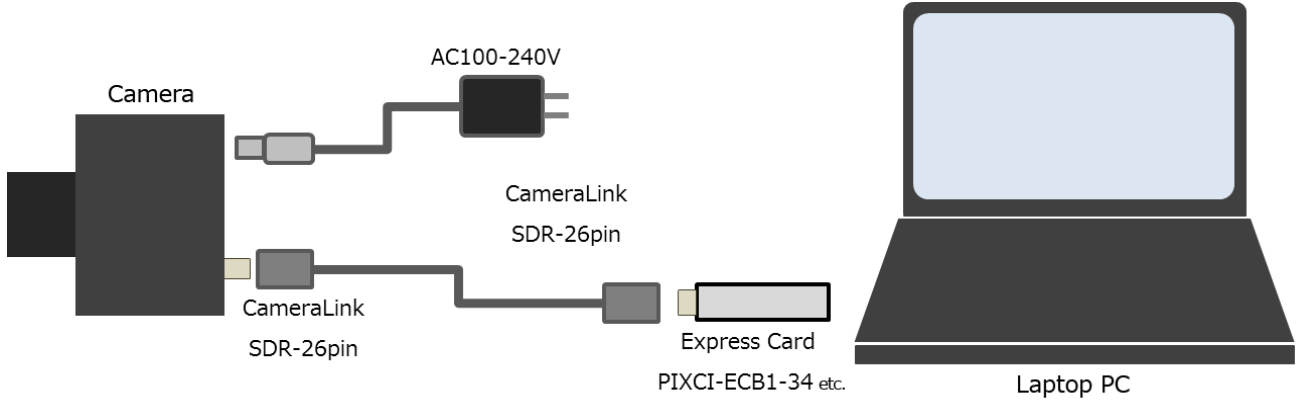

6. Specifications

6.1. Camera Specification

MODEL	ARTCAM-991SWIR-TEC-CL
Sensor Model	SONY IMX991-AABA-C
Effective Pixel Array	640(H) × 512(V)
Pixel Pitch	5[μ m] × 5[μ m]
Image Size	3.2[mm] × 2.56[mm] (Diagonal length: 4.1[mm], 1/4")
Spectral Range	400nm~1700nm
Shutter type	Global Shutter
S/N Ratio	51dB (for reference only)
Interface	Camera Link (Base Configuration)
Output connector	SDR26pin
A/D Resolution	12bit
Frame Rate	max 137fps (12bit only)
Exposure time	20.3 μ sec. ~ 2sec.
Gain (Analog/Digital)	0~420 ※DEFAULT VALUE : 0 (0~42[dB] ※DEFAULT VALUE : 0[dB])
Trigger	ON/OFF ※Default value : OFF
Mirroring	ON/OFF ※DEFAULT VALUE : OFF Vertical and Horizontal
Synchronization System	Internal Synchronization (preview mode) External Synchronization (trigger mode)
Lens Mount	C Mount
Power	DC12V External Input
Power Consumption	Under Approx.11W
Ambient Conditions	Operating Temperature/Humidity: 10~40° C / 10~80% (Non-condensing) Storage Temperature/Humidity: 0~60° C /10~95% (Non-condensing)
External Dimensions	71.6(W) × 61.5(H) × 78.0(D)mm ※Lens, Tripod mount and cables not included
Weight	About 450g

6.1.1. Analog / Digital Gain Settings

ARTCAM-990SWIR-TEC-CL is compatible with analog and digital gain.

Setting value of gain on software can be set from 0 ~ 420, and the gain will change from 0.0dB ~ 42.0dB accordingly. Gain can be calculated by the following formula:

$$\text{Gain [dB]} = \text{value} / 10.0[\text{dB}]$$

Digital gain will activate when setting value of gain > 180.

The graph below shows the relationship between setting value of gain and its magnification[dB].

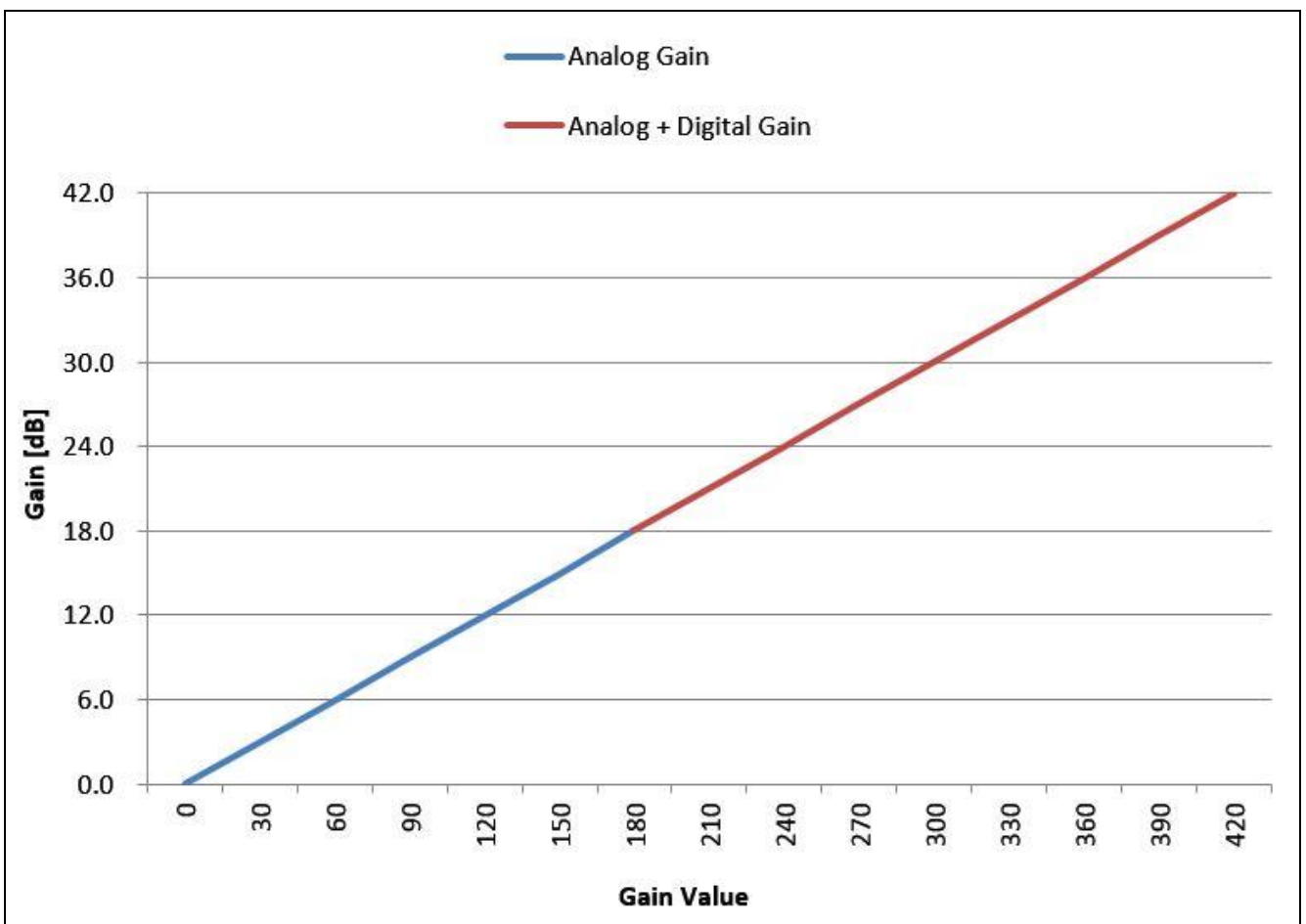

6.1.2. Shutter speed calculation

ARTCAM-991SWIR-TEC-CL allows for shutter speed control.

Shutter speed value can be calculated by the following formula:

$$\text{Shutter speed [us]} = \text{value} * 12.96[\text{us}]$$

6.1.3. Dimensional Outline

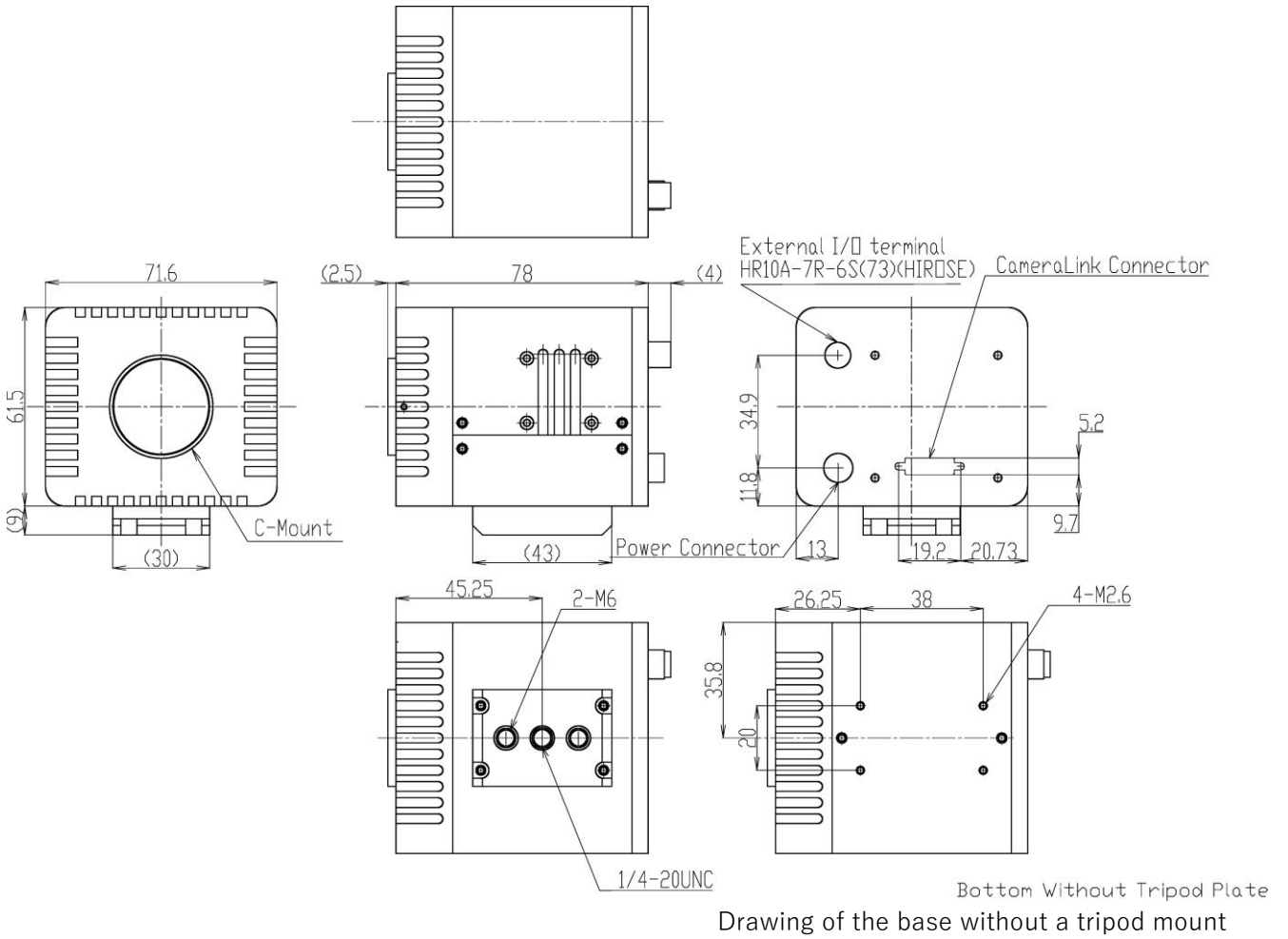

6.1.4. Sensor Package Information

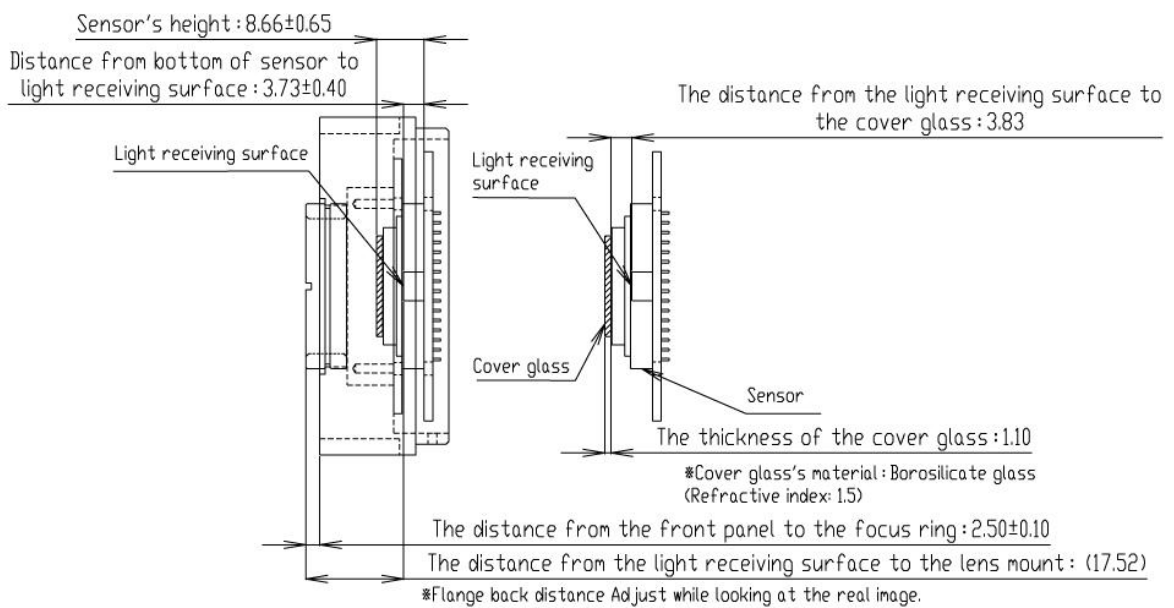

6.1.5. Sensor Position and the Light Receiving Surface

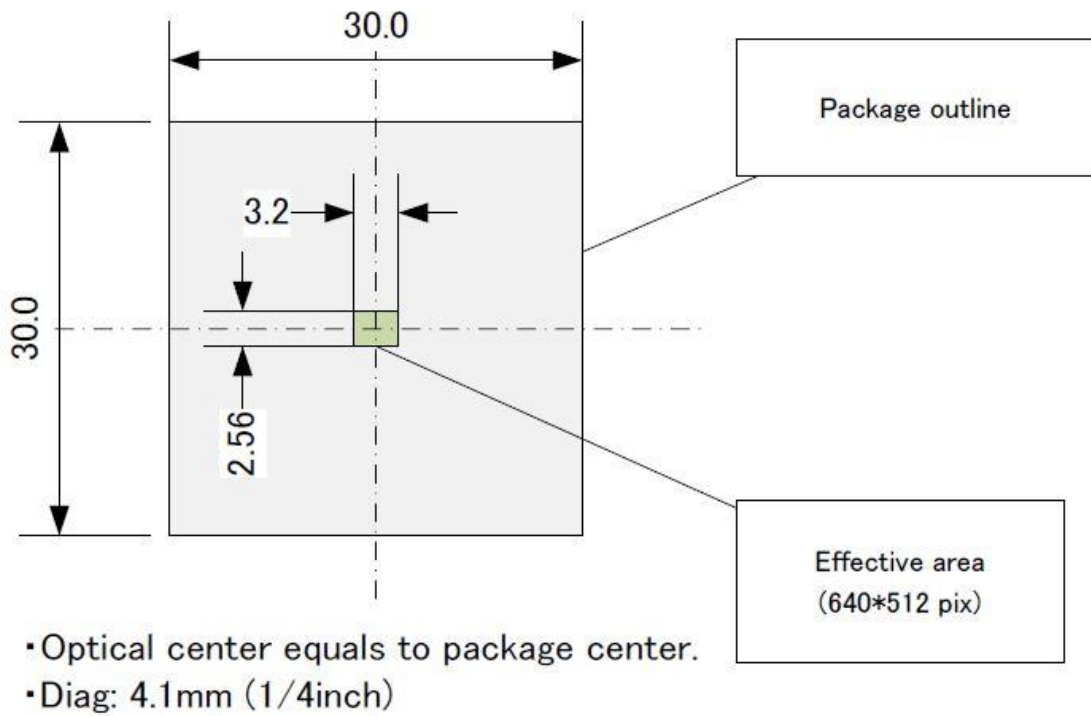

$$H = 5[\mu\text{m}] * 640 = 3200 [\mu\text{m}]$$

$$V = 5[\mu\text{m}] * 512 = 2560 [\mu\text{m}]$$

6.1.6. Field of Vision: Lens versus Sensor (For Reference Only)

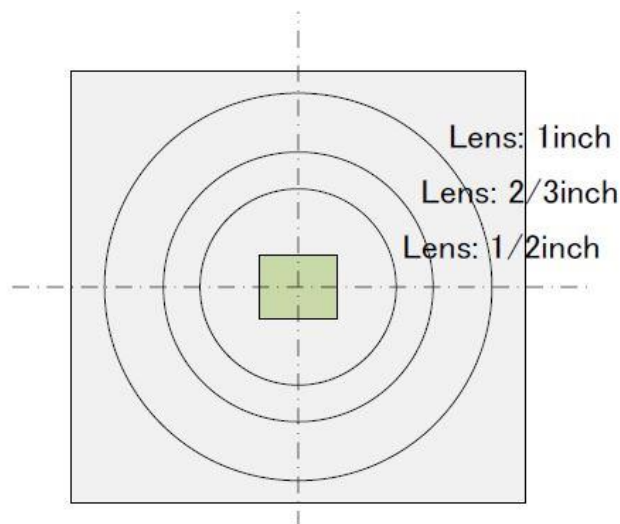

※The ratios of sensor size (diagonal) to lens size in the above illustrations are as follows:

1/2 inch = ϕ 8mm, 2/3 inch = ϕ 11mm, 1 inch = 15.8mm.

Please note that the actual field of view varies depending on different lens.

6.2. Spectral Sensitivity Characteristics

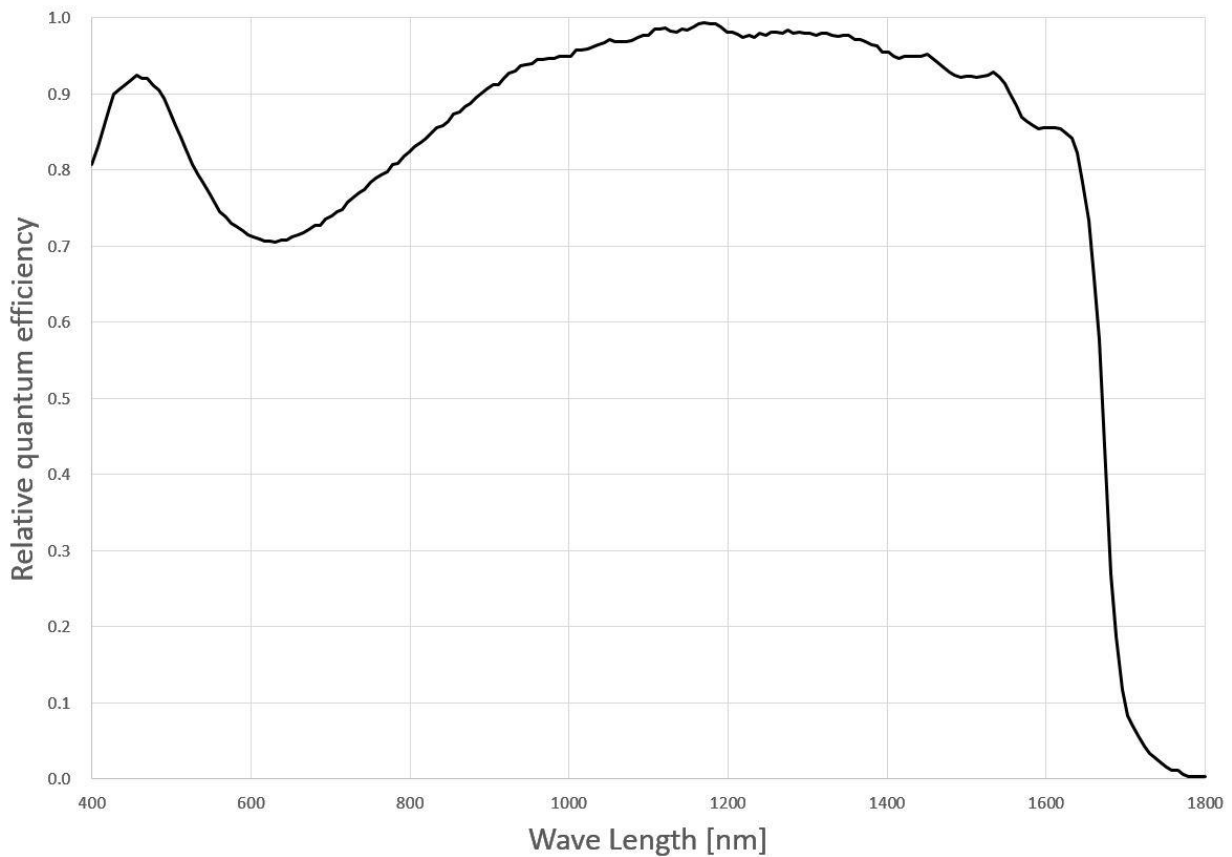

6.3. External Trigger Function

This camera has an external trigger electronic circuit, which is insulated by a photocoupler, and thus enables synchronized shooting by the input signal received from the external circuit.

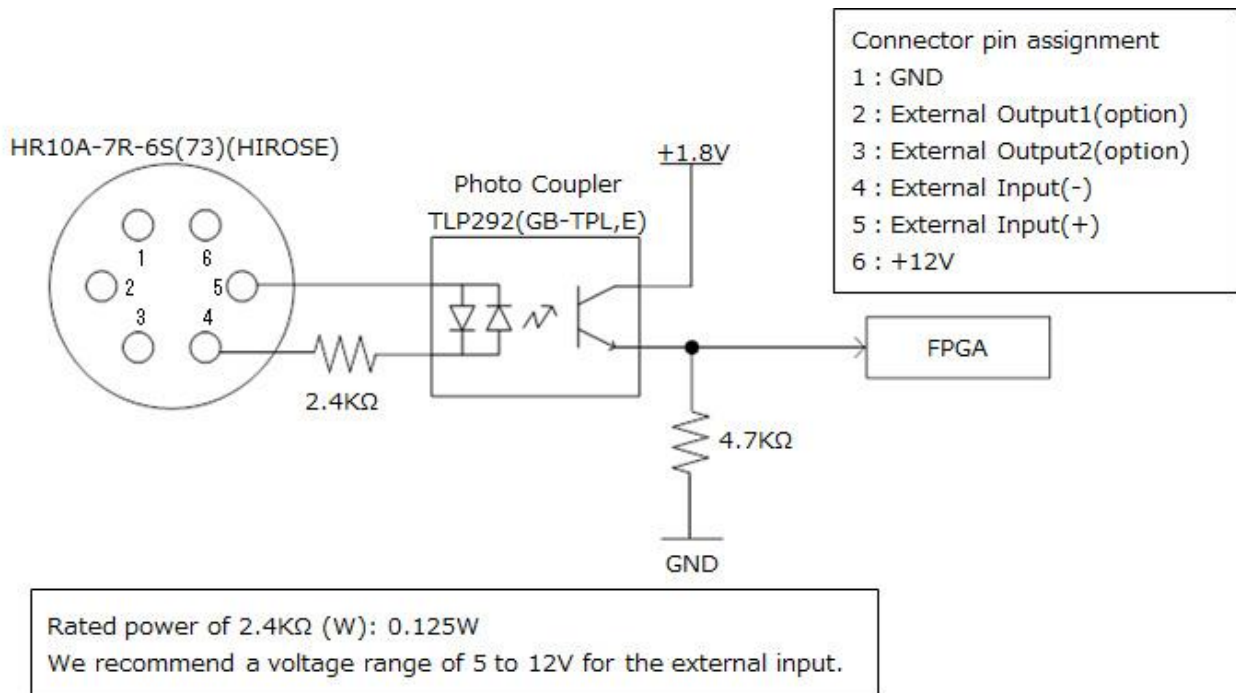

6.4. Trigger Timing

Details of Trigger Timing

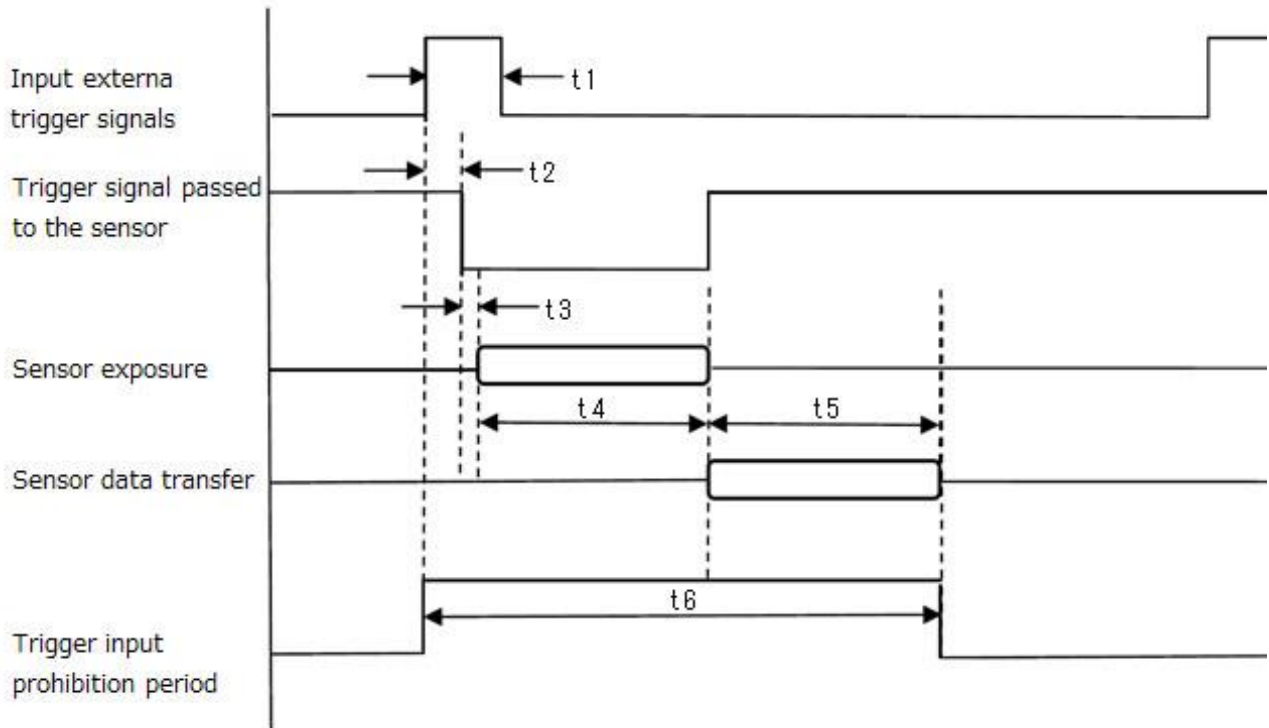

	items	Required time
t1	Effective trigger input pulse	$>10 \mu \text{ sec.}$
t2	From the rise of the external trigger input to the fall of the trigger signal passed to the sensor (Delay due to the photocoupler)	$<1 \mu \text{ sec.}$
t3	From the fall of the trigger signal passed to the sensor to the start of exposure	Max $0.13 \mu \text{ s}$
t4	Exposure time	Exposure time = The setting value of the Shutter speed*1H
t5	Time required for data transfer (from the sensor to the FPGA)	$(9+\text{Effective Vertical pixels}) * 1H$
t6	Trigger input prohibition period	$t2+t3+t4+t5$

※1H = $12.96 \mu \text{ sec.}$

※When input triggers continuously, please ensure that the trigger interval is more than t6.

7. Recommended System Requirements

- Camera Link Frame Grabber

It has been confirmed to work with boards manufactured by EPIX, Teledyne DALSA, National Instruments, and Aval Data.

All models made by EPIX have been confirmed to work, but other manufacturers have confirmed the operation of only some models.

Please confirm with us if you are using different grabber.

- PC

Please confirm the recommended requirement of the Camera Link frame grabber.

ARTRAY Co., LTD. Obtained ISO 9001: 2015 2018/9/17
1-17-5 Kouenjikota, Suginami-ku, Tokyo 166-0002 Japan
TEL: +81-3-3389-5488 FAX: +81-3-3389-5486
Email: sales@artray.us URL: www.artray.us

ARTRAY