

Feb 4, 2022

Ver1.00

USB3.0 InGaAs
NIR LINE SENSOR CAMERA
ARTCAM-L1024TNIR Series
INSTRUCTION BOOKLET

ARTCAM-L1024DTNIR
ARTCAM-L1024DBTNIR

ARTRAY CO., LTD.

ARTRAY

Contents

1. Attention	- 3 -
2. Introduction	- 6 -
3. Features.....	- 6 -
4. The Product.....	- 6 -
5. Connections.....	- 7 -
5.1. Connecting Method	- 7 -
6. Specifications.....	- 8 -
6.1. Specifications	- 8 -
6.2. Optional Functions.....	- 9 -
6.2.1. Trigger Shooting (optional)	- 9 -
6.2.2. External Output Function	- 9 -
6.2.3. About The Terminals On The Back Of The Camera	- 10 -
7. Dimensional Outline.....	- 11 -
7.1. ARTCAM-L1024DTNIR/L1024DBTNIR.....	- 11 -
8. Spectral Sensitivity Characteristics (Reference Value)	- 13 -
8.1. ARTCAM-L1024DTNIR/ L1024DBTNIR.....	- 13 -
9. System Requirements	- 14 -
9.1. Recommended System Requirements	- 14 -

1. Attention

■About this Manual

1. Before using the camera, please read this manual thoroughly.
2. Please keep this manual reachable and always refer to the contents when needed.
3. Please contact us if the manual is lost or damaged. We will provide a replacement.
4. We cannot guarantee the safety of improper uses of the camera.
5. For your safety, please follow the directions of this manual.
6. All contents are subject to change.
7. Images in this manual may have been simplified to be easier comprehended.
8. Please contact us if you find any unclear points or mistakes in this manual.
9. Quoting, copying or altering some or all parts of the manual without our permission is prohibited.
10. We are not responsible for any lost or damages on your profits due to the use of our products.
11. Please understand that our oversea branches do not provide maintenance or repair services.

■About the Icons

To keep the safety of the user, other people and their properties, please pay attention to the following icons.



Warning

If the user fails to follow the instruction, serious injury or death may occur.



Caution

If the user fails to follow the instruction, physical injury on human or damages on hardware may occur.

■ For Safe Use



Warning

● In following circumstances, please stop using the product and turn off the power immediately to prevent the risks of fires and electric shocks. If the product is defective, please contact us for repair or exchange. For your safety, please do not disassemble, modify or repair the camera on your own.

Please stop using the product and turn off the power immediately when:

- The product becomes smoky or gets extremely hot on the surface, or makes unusual smells or sounds.
- Foreign material or water gets into the product.
- The product falls and becomes damaged.

● Do not place the product on unstable surfaces. The product may be fallen and people may get hurt.



Caution

● Do not expose the product to steam or fumes to avoid electric shocks and fires.

● Do not leave the product in high temperature places such as inside of vehicles or under direct sunlight. High temperature may cause damages to the camera, or even cause fires.

● Do not cover the product with cloth or other materials. The product may get extremely hot and the heat may cause deformations on the parts or even cause fires.

● Please avoid dropping or shocking the product as the product may be damaged.

● Do not touch the cable with a wet hand. Such action may cause electric shocks.

● Please avoid continuously contacting the surface of the camera to your skin when the camera is being used. The surface temperature of the camera may cause burns.

■ Other Notices

● Please do not use the camera under strong lights such as sun light for a long period. Also, please do not expose the camera under strong lights even when the product is not being used because the sensor might be damaged.

■ Maintenance

- Wipe the dirt on surface with soft cloth or tissue paper. Do not use alcohol, thinner or benzene to avoid damaging the surface paints.

■ Export Control

This product is a List Control item subject to the Foreign Exchange and Foreign Trade Act and its relevant legislations No.1 10 (2) and (4). To export this product from Japan, obtaining export licenses from the Ministry of Economy, Trade and Industry is required. It is also necessary for our company to manage the information of users and the purposes of use. If the end users or purposes of use change after the purchase and thus cause the need to apply export licenses from Ministry of Economy, Trade and Industry, please contact the sales representative in advance.

■ Guarantee

To save the environment, we do not issue warranty in printed format. Instead, all records of the warranty periods, delivery dates and the customer information are well kept in our system.

For more details, please refer to the sites below:

Hardware Warranty: http://www.artray.us/download/artray_warranty.pdf

■ Dispose

To dispose this product, please return the camera to us. If you decide to dispose the camera without returning it us, please follow related regulations and have the camera disposed as an industrial waste. Please always keep records of the dispose, and make sure the disposed camera cannot be accessed or used by any 3rd party.

■ Limited Responsibility

We do not guarantee the functions of this product or the descriptions on this manual to be completely adapted to the users' end applications or marketing purposes. We are also not held responsible for any direct or indirect damages caused by our products under any circumstances.

Please do not use this product on applications that require high reliability. This product is not manufactured to be used as medical, nuclear, aerospace, transportation equipment or equipment that is highly related to human safety. We are not held responsible for any damages on the users' property, equipment or personal safety caused by this product.

2. Introduction

ARTCAM-L1024TNIR Series is a Near-infrared camera, which adopts InGaAs (Indium Gallium Arsenide) Linear Image Sensor and has high sensitivity to the wavelength band from 900nm to 1700nm

Adopting USB3.0 interface, thus enables direct data transfer to PC without a capture board or a host adapter card.

Also, since this series of cameras are equipped with onboard memories, it can avoid data missing and achieve complete bulk transfer.

3. Features

- NIR Detection with High Sensitivity

The adopted InGaAs Image Sensor has high sensitivity to the wavelength band from 900nm to 1700nm. Therefore, it is able to detect beyond the visible light region and visualizing things that are difficult to be seen by naked eyes or common CCD / CMOS cameras.

- USB3.0 Interface

Adopting USB3.0 interface, thus enables direct data transfer to PC without a capture board or a host adapter card.

4. The Product

- 1) Camera
- 2) USB3.0 cable (USB3.0 A – micro B Type 3.0m)
- 3) AC adapter (DC12V)
- 4) Viewer software and Device driver CD

<Option>

F Mount Lens (Correspond to NIR wavelength)

5. Connections

5.1. Connecting Method

Please connect the camera to the PC by using the attached USB3.0 cable.
Camera's power is supplied from the AC adapter (DC12V).

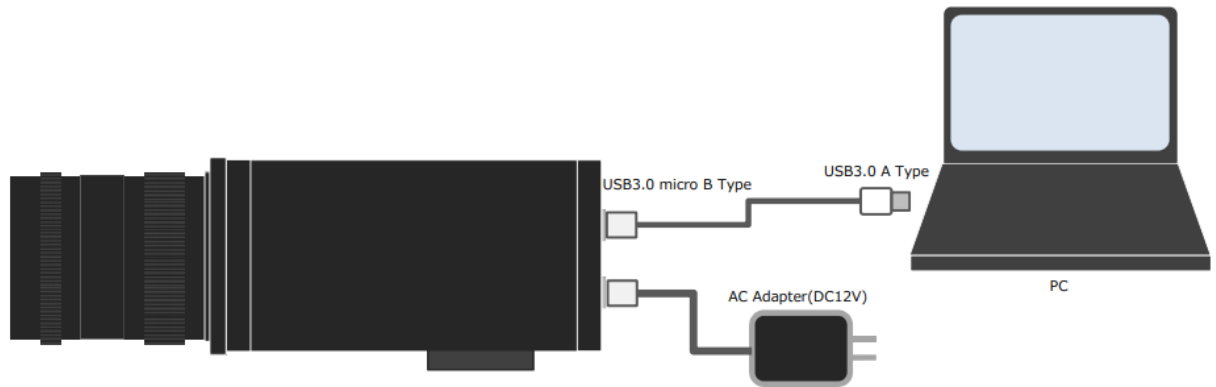

6. Specifications

6.1. Specifications

Items	ARTCAM-L1024DTNIR	ARTCAM-L1024DBTNIR
Sensor Type	G10768-1024D	G10768-1024DB
Model Number	InGaAs Linear image sensor	
Active Pixels	1024	
Active Image Size	25.6(H) × 0.1(V)mm	25.6(H) × 0.025(V)mm
Scanning Mode	Line scan	
Pixel Size	25(H) × 100(V) μm	25(H) × 25(V) μm
Wavelength	900 ~ 1700nm	
Line Rate	≒ 31.446kHz (max.)	
Data Rate	5MHz	
Saturation Capacity	0.25pC (Standard Value)	
A/D Resolution	14bit	
Interface	USB3.0 Bulk Transfer	
Synchronization Method	Internal Synchronization (Master mode) External Synchronization (trigger mode)	
Lens Mount	F Mount	
External I/O terminal	HR10A-7R-6S(73) (HIROSE)	
Power-supply Voltage	12.0V (±0.5V)	
Power Consumption	Approx. 6W	
Ambient Conditions	Operating Temperature / Humidity: 0 ~ 35° C / 10 ~ 80% (Non-water vapor condensation state) Storage Temperature / Humidity: 0 ~ 60° C / 10 ~ 95% (Non-water vapor condensation state)	
External Dimensions	71.6(W) × 61.5(H) × 109.5(D) mm ※Exclude lens, tripod mount and projections	
Weight	Approx.400g ※Exclude lens, tripod mount and projections	

6.2. Optional Functions

6.2.1. Trigger Shooting (optional)

External trigger function may be available based on your order options.

This camera has an external trigger electronic circuit, which is insulated by a photocoupler, and thus enables synchronized shooting by the input signal received from the external circuit.

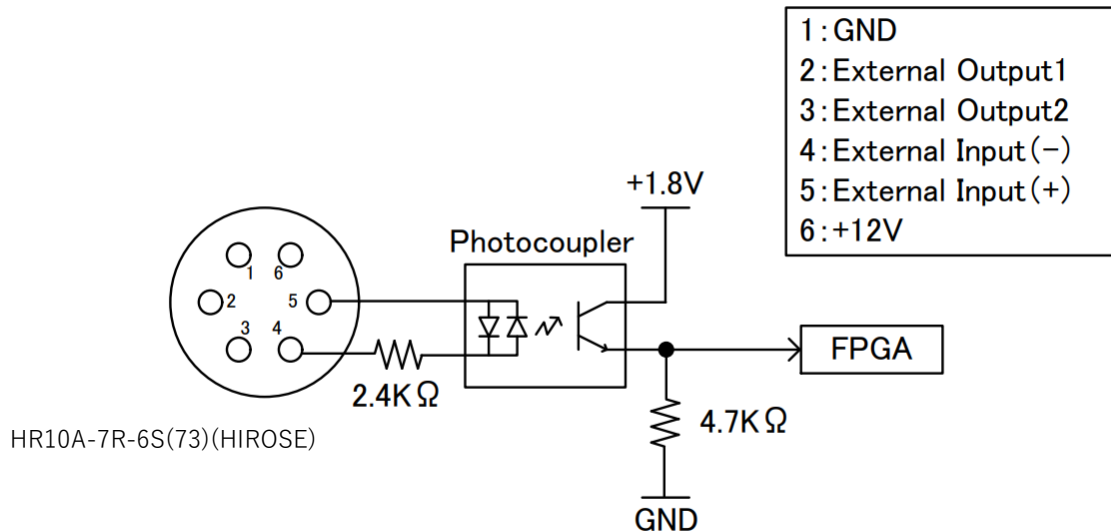

※The connector pin and pin assignment may be changed.

6.2.2. External Output Function

External output function may be available based on your order options.

It is possible to output and monitor the vertical synchronization, horizontal synchronization and the exposure time, which are controlled inside the FPGA.

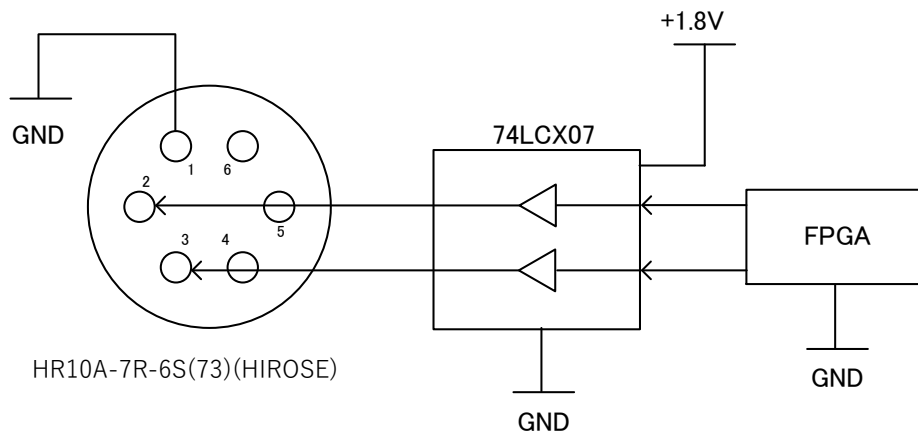

※The connector pin and pin assignment may be changed.

6.2.3. About The Terminals On The Back Of The Camera

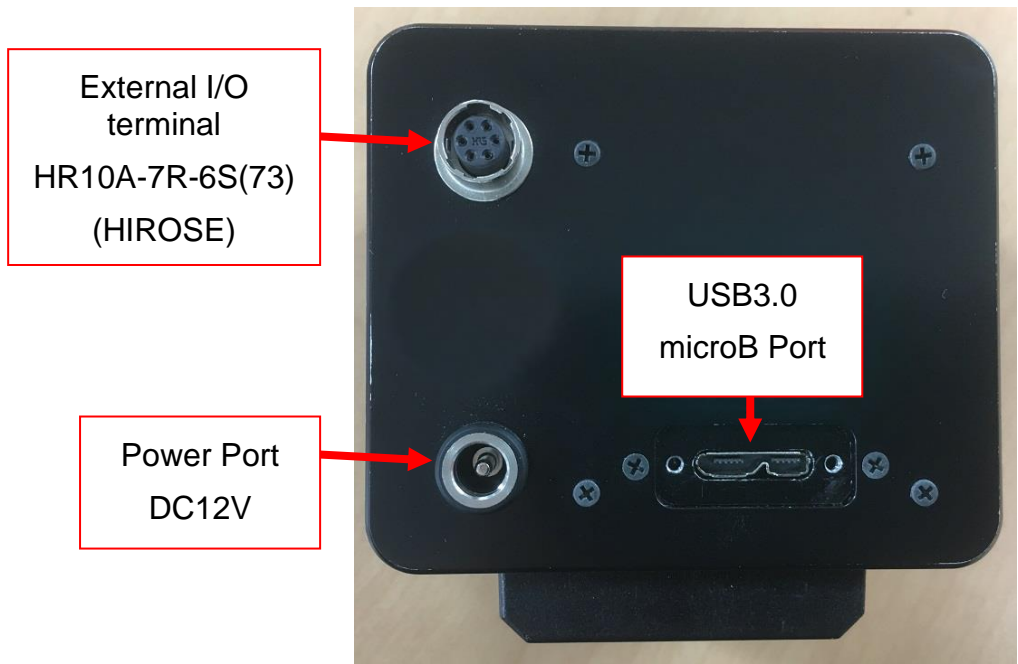

7. Dimensional Outline

7.1. ARTCAM-L1024DTNIR/L1024DBTNIR

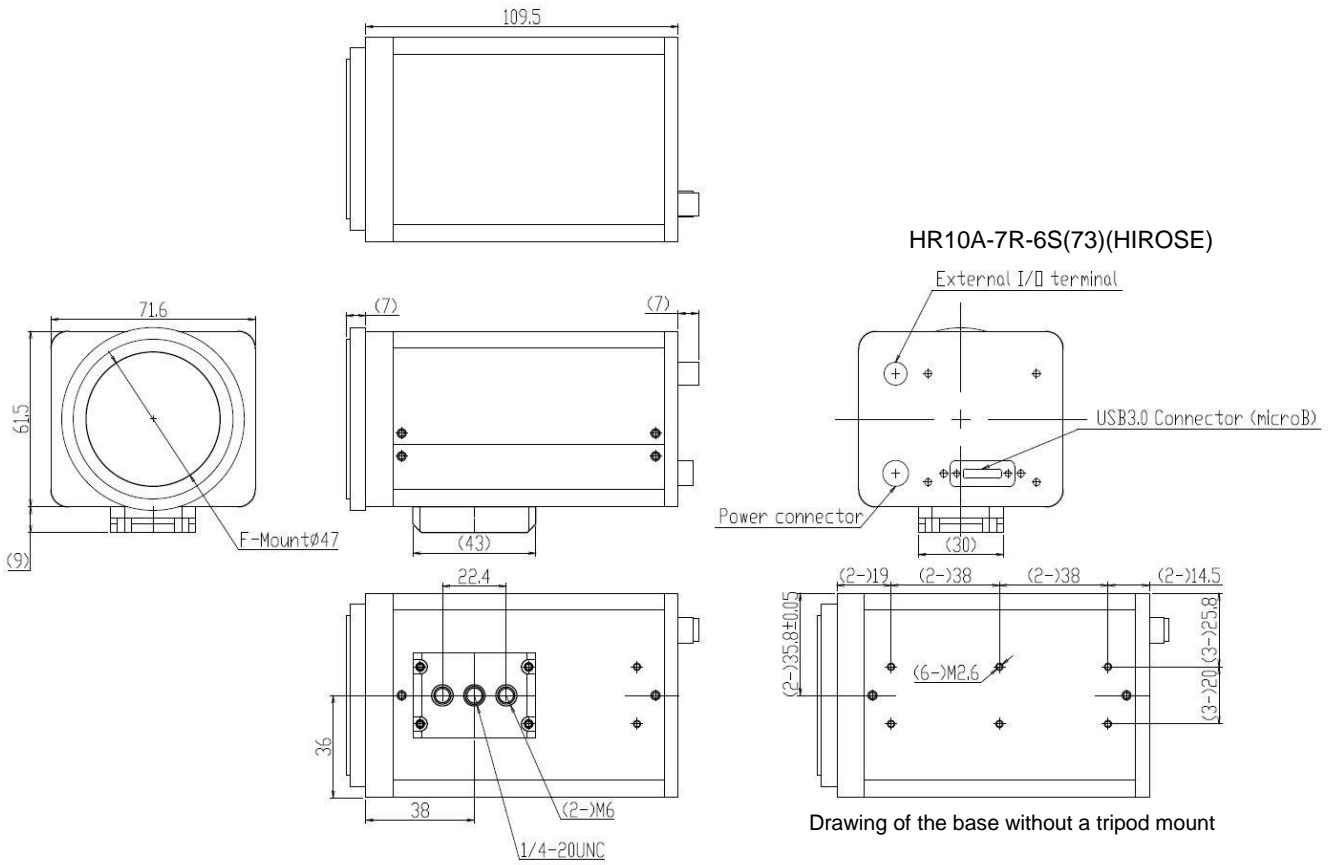

※The above specifications may change.

Illustrations of the relationship between the Mount and the Sensor surface

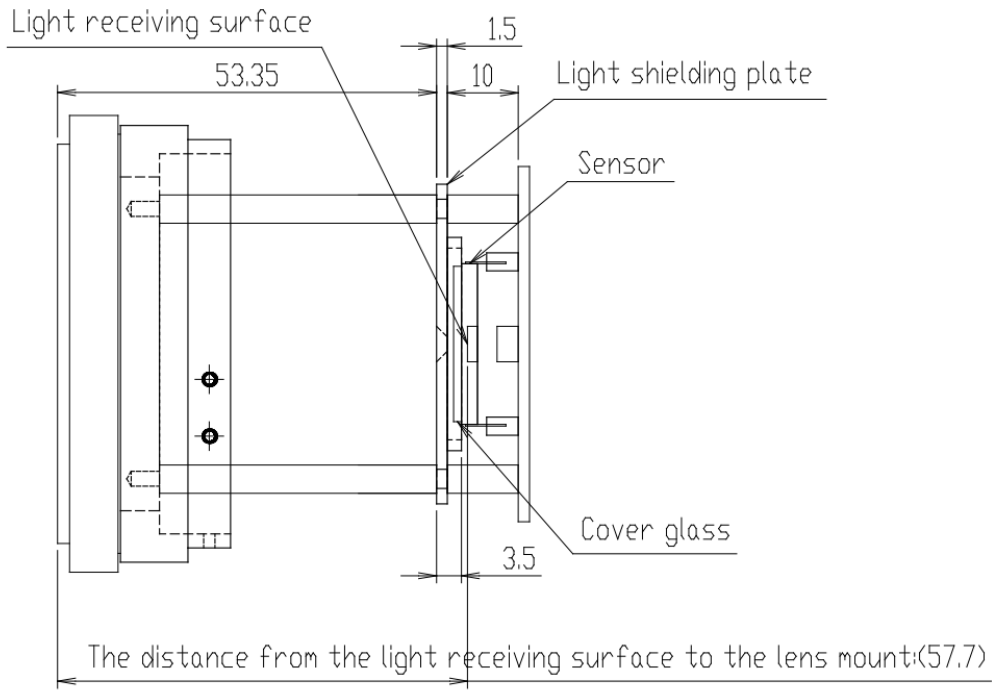

*Flange back distance Adjust while looking at the real image.

8. Spectral Sensitivity Characteristics (Reference Value)

8.1. ARTCAM-L1024DTNIR/ L1024DBTNIR

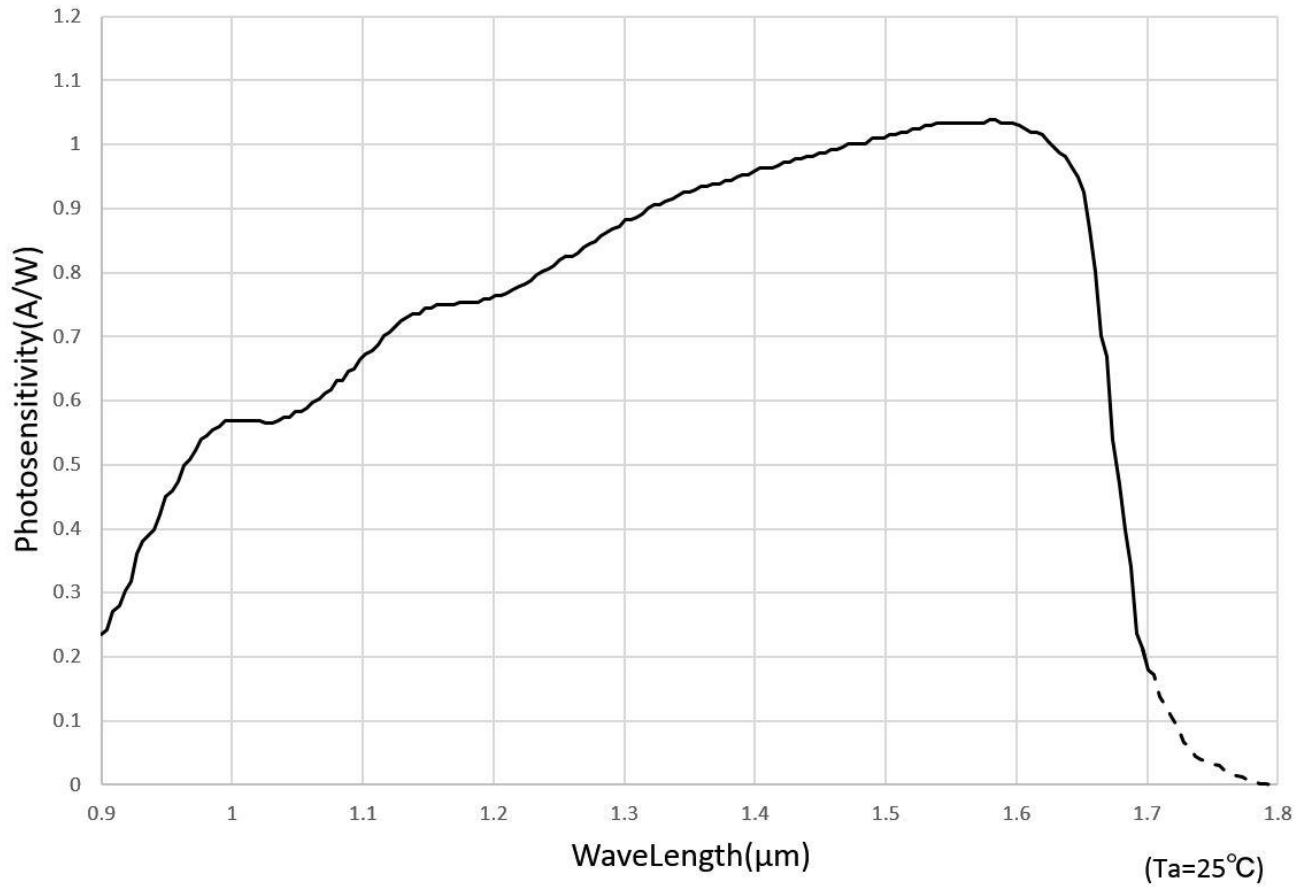

9. System Requirements

9.1. Recommended System Requirements

● Host Controller

This camera is applicable to USB 3.0.

Connecting to USB 2.0 host controller may cause low-speed or failure to function properly.

● CPU

The driver of this camera is applicable to computer architecture “x86” or “amd64”.

The specification of CPU effects directly the imaging process speed, therefore it is highly recommended to utilize a high-end CPU if possible.

● Memory

In the viewer software, there is a data buffer which can store 4 to 8 frames.

Therefore, it is necessary to keep spare space at least for 8 frames in the memory.

(For example, when using 1.3MP color camera, $1280 \times 1024 \times 3 \times 8$ [byte] = 30[MB] is necessary.)

It is highly recommended to keep enough memory space especially when using high resolution camera.

● OS

This camera is applicable only to the architecture of Windows NT (32bit/64bit).

Standard functions are confirmed with OS after Windows 7.

In addition, it is recommended to use Windows 10.



Caution

■ Please refer the restrictions below when you use ARTCAM series.

(1) Recommended System Requirements

If the system specifications do not meet the requirements recommended above, it may be difficult to run at the maximum frame rate.

(2) Use of other USB3.0 Hardware

The data on our camera/converter is transferred in bulk mode. For this reason, when using our camera/converter, please avoid using other bulk transferred USB3.0 hardware such as Memory stick, External HDD, External DVD, CDROM etc.

As a solution, we recommend installing a PCI USB host card to the PC and connect external USB hardware to this port only.

(3) USB3.0 Cable Extension

We cannot guarantee the functionality of the USB3.0 camera if the user adopts USB3.0 extension cables or repeaters which are not confirmed by us. With the extension cables or repeaters, the bandwidth of transfer may differ, and thus caused malfunctions such as a low frame rate or recognition failure on the camera.

What may cause the problem is that the regulation of the power lines becomes not enough, and so causes impedance mismatch on data signals.

*For the recommended extension cable, please contact our sales department.

(TEL: +81-3389-5488)

ARTRAY CO., LTD. Obtained ISO 9001: 2015 2018/9/17

1-17-5 Kouenjikota, Suginami-ku, Tokyo 166-0002 Japan

Tel: +81-3-3389-5488

Fax: +81-3-3389-5486

Email: sales@artray.us

URL: www.artray.us