

Feb 4, 2022

Ver1.02

USB3.0 InGaAs LINESCAN CAMERA ARTCAM-LTNIR series INSTRUCTION BOOKLET

512 pixels ARTCAM-L512TNIR

256 pixels ARTCAM-L256TNIR

ARTRAY
ARTRAY CO., LTD.

Contents

1. Attention	- 3 -
2. Introduction	- 6 -
3. Main Features	- 6 -
4. The Product.....	- 6 -
5. Connect the Camera	- 7 -
5.1. How to Connect a Camera.....	- 7 -
5.2. Shutter Speed.....	- 7 -
6. Specifications.....	- 8 -
7. Spectral sensitivity characteristics	- 9 -
7.1. ARTCAM-L512TNIR/ARTCAM-L256TNIR.....	- 9 -
8. External Dimensions	- 10 -
8.1. ARTCAM-L512TNIR/ARTCAM-L256TNIR.....	- 10 -
9. Optional Functions	- 11 -
9.1. External trigger function	- 11 -
9.2. External output function	- 11 -
9.3. Each terminal information on the back of the camera	- 12 -
10. System Requirements	- 13 -
10.1. Recommended System Requirements	- 13 -

1. Attention

■ About this manual

1. Before using the camera, please read this manual thoroughly.
2. Please keep this manual reachable and always refer to the contents when needed.
3. Please contact us if the manual is lost or damaged. We will provide a replacement.
4. We cannot guarantee the safety of improper uses of the camera.
5. For your safety, please follow the directions of this manual.
6. All contents are subject to change.
7. Images in this manual may have been simplified to be easier comprehended.
8. Please contact us if you find any unclear points or mistakes in this manual.
9. Quoting, copying or altering some or all parts of the manual without our permission is prohibited.
10. We are not responsible for any lost or damages on your profits due to the use of our products.
11. Please understand that our oversea branches do not provide maintenance or repair services.

■ About the Icons

To keep the safety of the user, other people and their properties, please pay attention to the following icons.



Warning

If the user fails to follow the instruction, serious injury or death may occur.



Caution

If the user fails to follow the instruction, physical injury on human or damages on hardware may occur.

■ For Safe Use



Warning

● In following circumstances, please stop using the product and turn off the power immediately to prevent the risks of fires and electric shocks. If the product is defective, please contact us for repair or exchange. For your safety, please do not disassemble, modify or repair the camera on your own.

Please stop using the product and turn off the power immediately when:

- The product becomes smoky or gets extremely hot on the surface, or makes unusual smells or sounds.
 - Foreign material or water gets into the product.
 - The product falls and becomes damaged.
- Do not place the product on unstable surfaces. The product may be fallen and people may get hurt.



Caution

- Do not expose the product to steam or fumes to avoid electric shocks and fires.
- Do not leave the product in high temperature places such as inside of vehicles or under direct sunlight. High temperature may cause damages to the camera, or even cause fires.
- Do not cover the product with cloth or other materials. The product may get extremely hot and the heat may cause deformations on the parts or even cause fires.
- Please avoid dropping or shocking the product as the product may be damaged.
- Do not touch the cable with a wet hand. Such action may cause electric shocks.
- Please avoid continuously contacting the surface of the camera to your skin when the camera is being used. The surface temperature of the camera may cause burns.

■ Other Notices

- Please do not use the camera under strong lights such as sun light for a long period. Also, please do not expose the camera under strong lights even when the product is not being used because the sensor might be damaged.

■ Maintenance

- Wipe the dirt on surface with soft cloth or tissue paper. Do not use alcohol, thinner or benzene to avoid damaging the surface paints.

■ Export Control

This product is a List Control item subject to the Foreign Exchange and Foreign Trade Act and its relevant legislations No.1 10 (2) and (4). To export this product from Japan, obtaining export licenses from the Ministry of Economy, Trade and Industry is required. It is also necessary for our company to manage the information of users and the purposes of use. If the end users or purposes of use change after the purchase and thus cause the need to apply export licenses from Ministry of Economy, Trade and Industry, please contact the sales representative in advance.

■ Guarantee

To save the environment, we do not issue warranty in printed format. Instead, all records of the warranty periods, delivery dates and the customer information are well kept in our system.

For more details, please refer to the sites below:

Hardware Warranty: http://www.artray.us/download/artray_warranty.pdf

■ Dispose

To dispose this product, please return the camera to us. If you decide to dispose the camera without returning it us, please follow related regulations and have the camera disposed as an industrial waste. Please always keep records of the dispose, and make sure the disposed camera cannot be accessed or used by any 3rd party.

■ Limited Responsibility

We do not guarantee the functions of this product or the descriptions on this manual to be completely adapted to the users' end applications or marketing purposes. We are also not held responsible for any direct or indirect damages caused by our products under any circumstances.

Please do not use this product on applications that require high reliability. This product is not manufactured to be used as medical, nuclear, aerospace, transportation equipment or equipment that is highly related to human safety. We are not held responsible for any damages on the users' property, equipment or personal safety caused by this product.

2. Introduction

ARTCAM-LTNIR series include 2 kinds of NIR camera which adopts a 512 / 256 InGaAs (Indium gallium arsenide) sensor. The cameras have a high sensitive spectral response from 950 nm to 1700 nm.

ARTCAM-LTNIR series adopts USB3.0 interface, so image data can be delivered to PC directly without a capture board. Also, this camera is equipped with an on board memory which avoid data missing during transfer.

3. Main Features

●NIR Detection with High Sensitivity

The InGaAs sensor can detect radiation invisible to human eyes and CCD/CMOS cameras in the wavelength range between 950 nm to 1700 nm band.

●High Date Rate

ARTCAM-L512TNIR uses a higher resolution sensor of 512 pixels and delivers image at maximum 8150 Hz scan/sec.

ARTCAM-L256TNIR uses 256 pixels sensor and delivers high-speed imaging maximum 14000Hz scan/sec.

●USB3.0 Interface

This camera adopts USB3.0 interface, so the data can be delivered to PC directly. No capture board is needed.

●Included Software Development Kit

When developing image processing software, a software development kit that enables you to acquire Camera image acquisition and camera control are possible with other applications is included as standard.

You can also download it from the website below.

http://www.artray.us/download_sdk.html

4. The Product

- 1) Camera
- 2) USB3.0 Cable Type A-microB connector cable, 3m approx.
- 3) AC adapter (DC12V)
- 4) Introduction Booklet

<Options>

- 1) NIR Lenses (C Mount Lens)

5. Connect the Camera

5.1. How to Connect a Camera

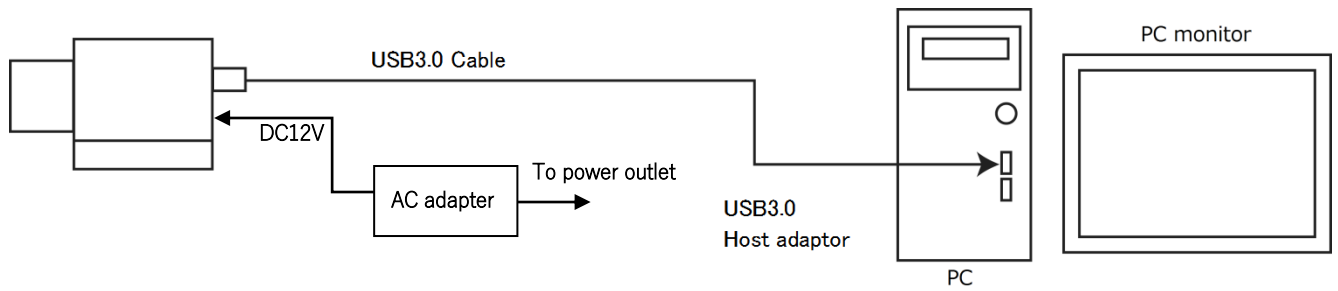

5.2. Shutter Speed

The shutter speed can be set with standard viewer software.

Model	Method
ARTCAM-L512TNIR	Range : 89~5039(Exposure Time : 10~1000 μ sec) Exposure Time=(Shutter Value - 39) x 0.2 [μ sec]
ARTCAM-L256TNIR	TBD

6. Specifications

	ARTCAM-L512TNIR	ARTCAM-L256TNIR
Sensor Type	InGaAs linear Image Sensor	
Number of effective pixels	512	256
Resolution	512	256
Active Imager Size	12.8(H)x0.025(V)mm	12.8(H)x0.05(V)mm
Scan Mode	Line Scan	
Pixel Size	25(H)x25(V) μ m	50(H)x50(V) μ m
Detected Wavelength	950~1700nm	
scan/sec	8150Hz	14000Hz
Pixel Rate	5MHz	
Sensitivity	0.82 A/W	
Full Well Capacity	2800Ke-	
A/D Resolution	14bit	
Interface	USB3.0 Bulk Transfer	
Synchronization System	Internal Synchronization / External Trigger Synchronization	
Lens Mount	C Mount	
External I/O terminal	HR10A-7R-6S(73) (HIROSE)	
Power	DC12V	
Power Consumption	Under Approx.5W	
Ambient Conditions	Operating Temperature/Humidity : 0~35° C/10~80%(Non condensing) Storage Temperature/Humidity : 0~60° C/10~95%(Non condensing)	
External Dimensions	71.6(W)x61.5(H)x51.5(D)mm *Lens, tripod and cables not included	
Weight	About 237 g	About 237 g

Depending on lens you use, our product might not reach the best condition and problems, such as the low resolution and lightness, might occur.

Please consult our sales representative for the recommended lenses.

7. Spectral sensitivity characteristics

7.1. ARTCAM-L512TNIR/ARTCAM-L256TNIR

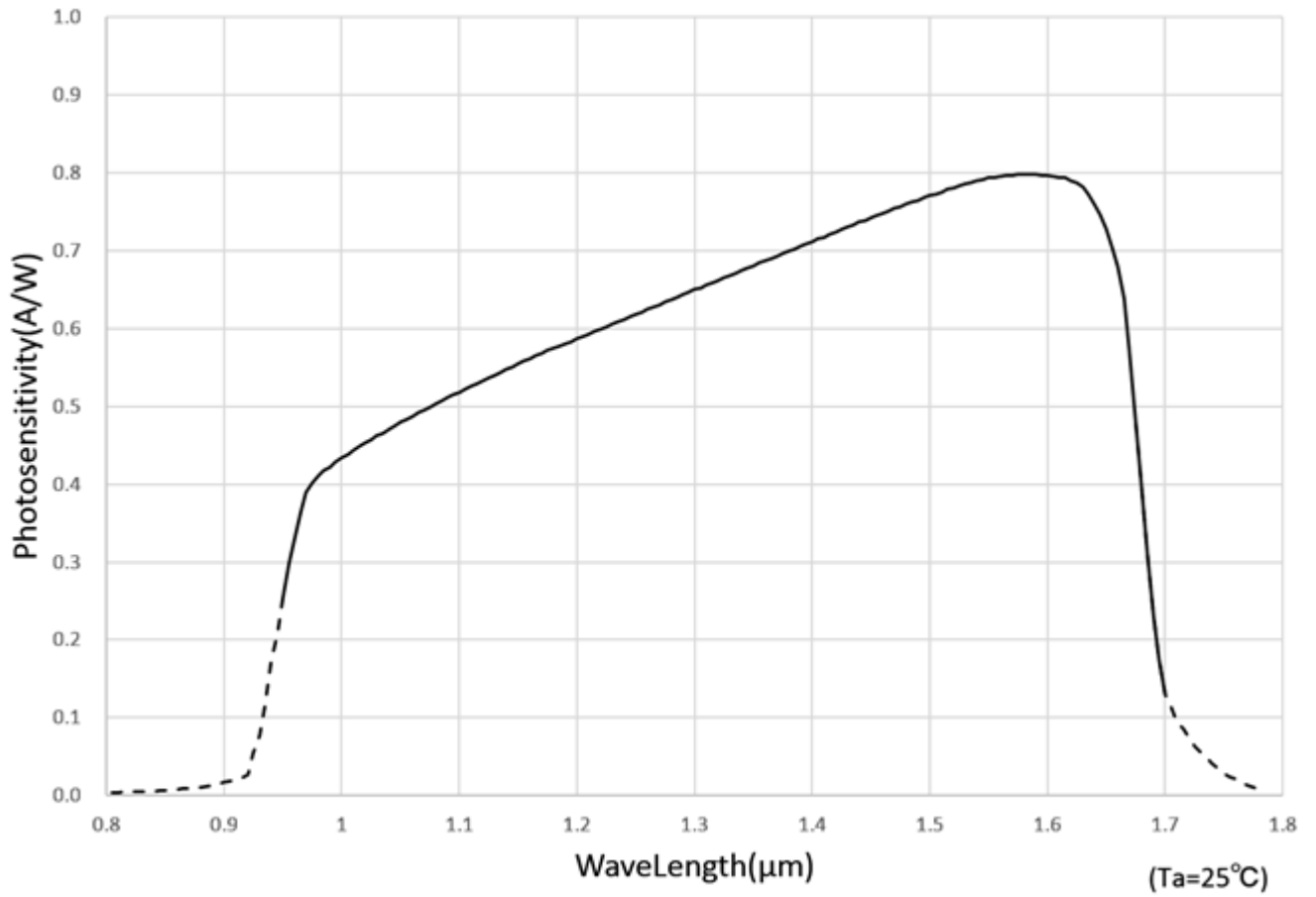

8. External Dimensions

8.1. ARTCAM-L512TNIR/ARTCAM-L256TNIR

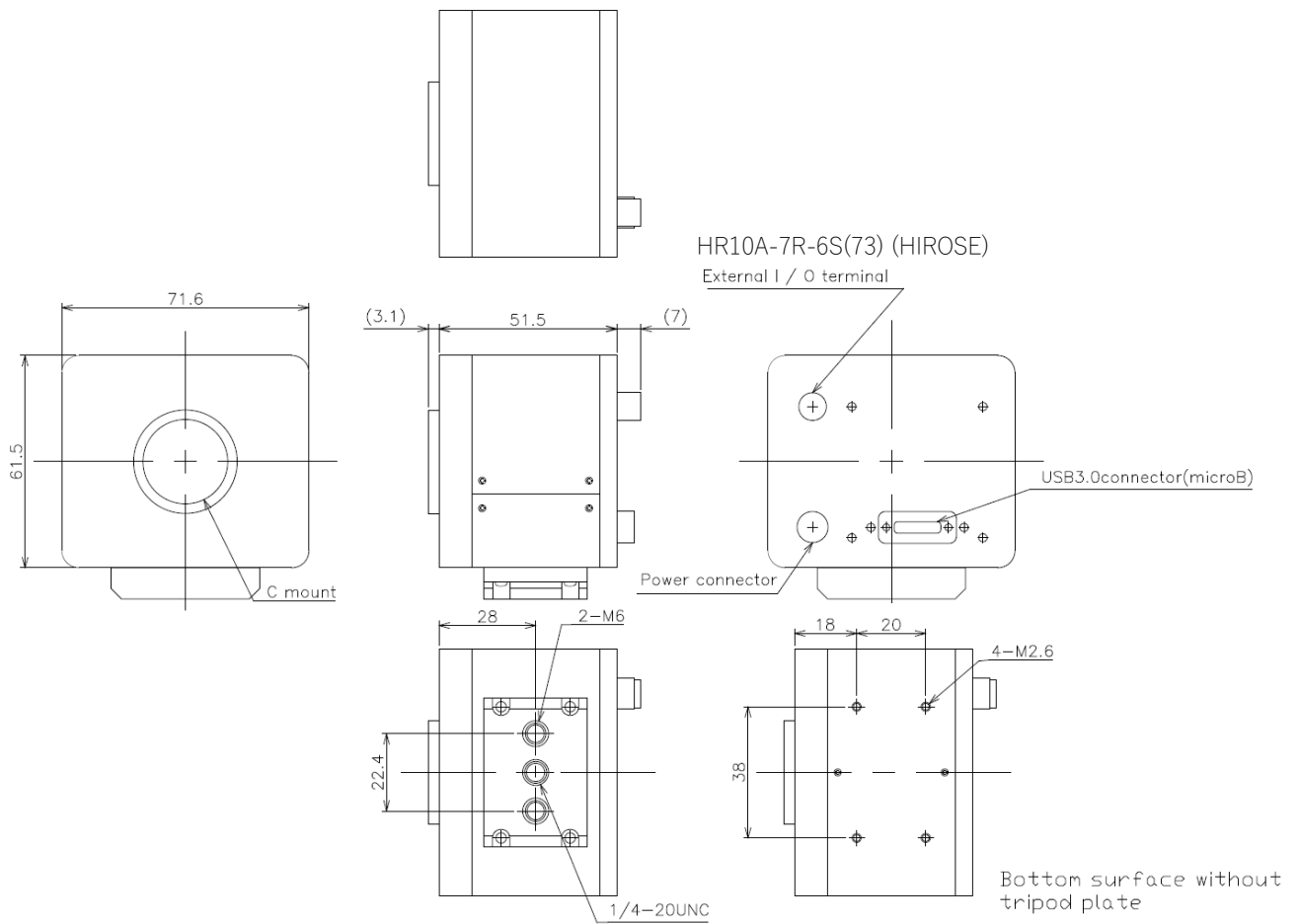

※ Specifications are subject to change.

9. Optional Functions

9.1. External trigger function

ARTCAM-TNIR series are designed with external trigger.

(Following input circuit diagram applies to L512TNIR, L256TNIR)

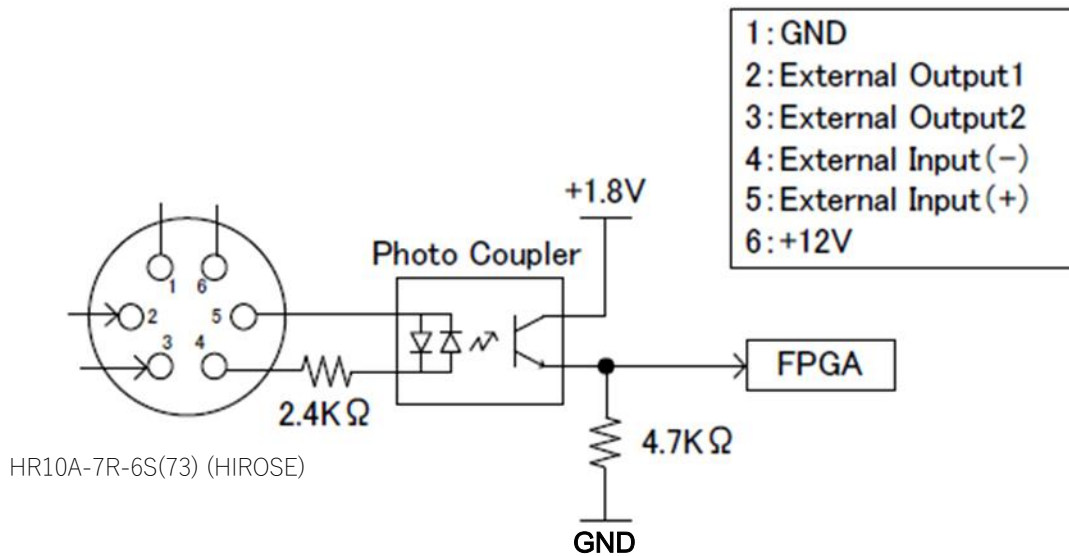

※ The connector pin assignment is subject to change.

9.2. External output function

You can use the external output function by factory option.

It is possible to output and monitor the vertical synchronization, horizontal synchronization, exposure time etc controlled inside the FPGA.

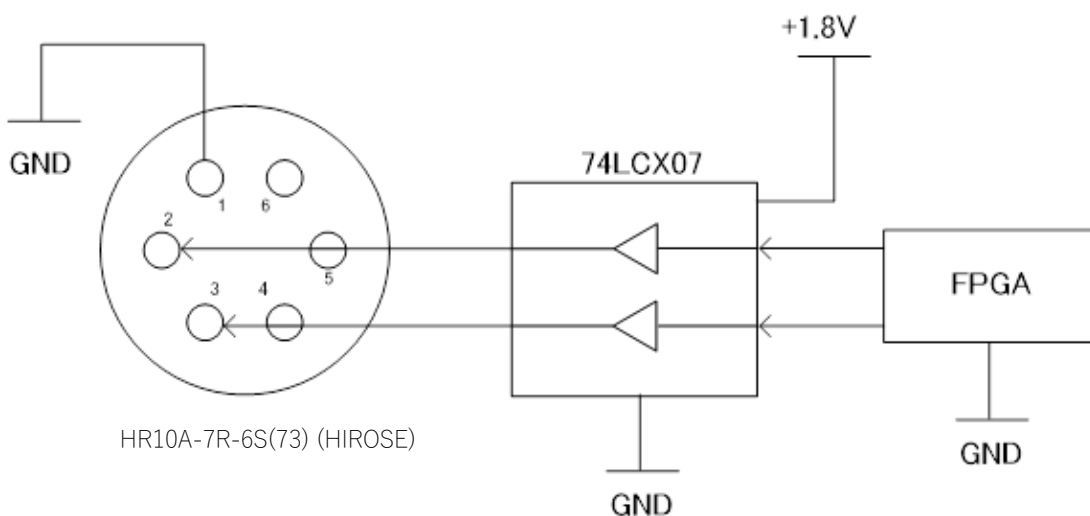

※ The connector pin assignment is subject to change.

9.3. Each terminal information on the back of the camera

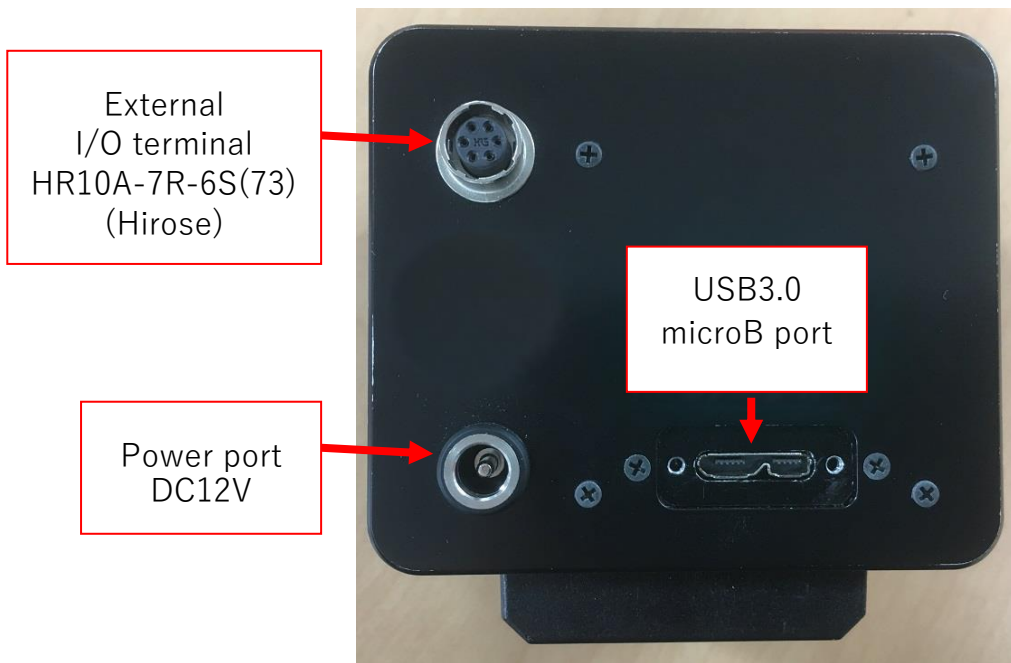

10. System Requirements

10.1. Recommended System Requirements

● Host Controller

This camera is applicable to USB 3.0.

Connecting to USB 2.0 host controller may cause low-speed or failure to function properly.

● CPU

The driver of this camera is applicable to computer architecture “x86” or “amd64”.

The specification of CPU effects directly the imaging process speed, therefore it is highly recommended to utilize a high-end CPU if possible.

● Memory

In the viewer software, there is a data buffer which can store 4 to 8 frames.

Therefore, it is necessary to keep spare space at least for 8 frames in the memory.

(For example, when using 1.3MP color camera, $1280 \times 1024 \times 3 \times 8$ [byte] = 30[MB] is necessary.)

It is highly recommended to keep enough memory space especially when using high resolution camera.

● OS

This camera is applicable only to the architecture of Windows NT (32bit/64bit).

Standard functions are confirmed with OS after Windows 7.

In addition, it is recommended to use Windows 10.



Caution

■ Please refer the restrictions below when you use ARTCAM series.

(1) Recommended System Requirements

If the system specifications do not meet the requirements recommended above, it may be difficult to run at the maximum frame rate.

(2) Use of other USB3.0 Hardware

The data on our camera/converter is transferred in bulk mode. For this reason, when using our camera/converter, please avoid using other bulk transferred USB3.0 hardware such as Memory stick, External HDD, External DVD, CDROM etc.

As a solution, we recommend installing a PCI USB host card to the PC and connect external USB hardware to this port only.

(3) USB3.0 Cable Extension

We cannot guarantee the functionality of the USB3.0 camera if the user adopts USB3.0 extension cables or repeaters which are not confirmed by us. With the extension cables or repeaters, the bandwidth of transfer may differ, and thus caused malfunctions such as a low frame rate or recognition failure on the camera.

What may cause the problem is that the regulation of the power lines becomes not enough, and so causes impedance mismatch on data signals.

*For the recommended extension cable, please contact our sales department.

(TEL: +81-3389-5488)

ARTRAY Co., LTD. Obtained ISO 9001: 2015 2018/9/17

1-17-5 Kouenjikota, Suginami-ku, Tokyo 166-0002 Japan

TEL: +81-3-3389-5488

FAX: +81-3-3389-5486

Email: sales@artray.us

URL: www.artray.us

ARTRAY