

USB2.0 Ultraviolet CMOS Camera

ARTCAM-UV-WOM Series

INSTRUCTION BOOKLET

| | |
|---------------|------------------|
| 1.3 M pixels | ARTCAM-130UV-WOM |
| 0.92 M pixels | ARTCAM-092UV-WOM |

Contents

| | |
|---|----|
| 1. Attention | 3 |
| 2. Introduction | 6 |
| 3. Main Features | 6 |
| 4. The Product | 7 |
| 5. Connect the Camera | 7 |
| 6. Specifications | 8 |
| 7. External Dimensions | 11 |
| 8. Spectral Sensitivity Characteristics | 12 |
| 9. Recommended PC | 13 |

1. Attention

■About this manual

1. Before using the camera, please read this manual thoroughly and use the camera properly.
2. Please keep this manual reachable and always refer to the contents when needed.
3. Please contact us if the manual is lost or damaged. We will provide a replacement.
4. We cannot guarantee the safety of improper uses of the camera.
5. For your safety, please follow the directions of this manual.
6. All contents are subject to change.
7. Images in this manual may have been simplified for easier comprehension.
8. Please contact us if you find any unclear points or mistakes in this manual.
9. Quoting, copying or altering some or all parts of the manual without our permission is prohibited.
10. We are not responsible for any losses or damages on your profits due to the use of our products.
11. Please understand that our oversea branches do not provide maintenance or repair services.

■About the Icons

To keep the safety of the user, other people and their properties, please pay attention to the following icons.



Warning

If the user fails to follow the instruction, serious injury or death may occur.



Caution

If the user fails to follow the instruction, physical injury on human or damages on hardware may occur.

■For Safe Use



Warning

●In following circumstances, please stop using the product and turn off the power immediately to prevent the risks of fires and electric shocks. If the product is defective, please contact us for repair or exchange. For your safety, please do not disassemble, modify or repair the camera on your own.

Please stop using the product and turn off the power immediately when:

- The camera emits smoke or gets extremely hot on the surface, or gives unusual smells or sounds.
 - Extraneous material or water gets into the product.
 - The product falls and gets damaged.
- Do not put the product on unstable surfaces. The product may fall and cause people hurt.



Caution

- Do not expose the product to steam or fumes to avoid electric shocks and fires.
- Do not leave the product in heated places such as near fire, inside of vehicles or under the direct sunlight. High temperature may cause damages to the camera, or even cause fires.
- Do not cover the product with cloths or other materials. The product may get extremely hot and the heat may cause deformations on the parts or even cause fires.
- Please avoid dropping or giving shock on the product as the product may be damaged.
- Do not touch the cable with a wet hand. Such action may cause electric shocks.
- When the camera is working, please avoid touching the surface of the camera for a long while. The surface temperature of the camera may cause burns.

■Other Notices

●Please do not use the camera under strong lights such as sun light for a long while. Also, please do not expose the camera under strong lights even when the product is not being used because the sensor might be damaged.

■Maintenance

●Wipe the dirt on surface with soft cloth or tissue paper. Do not use alcohol, thinner or benzene to avoid damaging the surface paints.

■Electro Magnetic Interference

●The camera may interference with electronic devices such as TV and radio. Please do not place the camera next to such equipment.

■Export Control

The Government of Japan controls military sensitive goods and technologies including relevant dual-use goods and technologies.

This product is a Catch-all Control item subject to the Foreign Exchange and Foreign Trade Act and its relevant legislations. Except for exporting to the 26 white countries designated in the Cabinet Order, export licenses are required if the products are going to be used for military use or if the end user of the product is related to all kinds of military activities. If your circumstances cause the need to apply export licenses, please notify us before you place orders. Also, please notify us in advance if the end users or purposes of use change after the purchase and thus cause the need to apply export licenses.

*The 26 white countries not under the UNSC Arms Embargo:

Argentina, Australia, Austria, Belgium, Bulgaria, Canada, Czech Republic, Denmark, Finland, France, Germany, Greece, Hungary, Ireland, Italy, Luxemburg, Netherlands, New Zealand, Norway, Poland, Portugal, Spain, Sweden, Switzerland, United Kingdom, and United States.

About the Japanese Security Export Controls, please refer to the webpage for Security Export Control Policy, the Ministry of Economy, Trade and Industry:

<http://www.meti.go.jp/policy/anpo/englishpage.html>

■Guarantee

To save the environment, we do not issue warranty in printed format. Instead, all records of the warranty periods, delivery dates and the customer information are well kept in our system.

For more details, please refer to the following link:

Hardware Warranty: http://www.artray.us/download/artray_warranty.pdf

■Limited Responsibility

●We do not guarantee the functions of this product or the descriptions on this manual to be completely adapted to the users' end applications or marketing purposes. We are also not held responsibility for any direct or indirect damages caused by our products under any circumstances.

●Please do not use this product for a task that require high reliability. This product is not manufactured to be used as medical, nuclear, aerospace, transportation equipment or equipment or that is highly related to human safety. We are not held responsibility for any damages on the users' property, equipment or personal safety caused by this product.

■Disposal

●To dispose this product, please return the camera to us. If you decide to dispose the camera without returning it to us, please follow related regulations and have the camera disposed as an industrial waste. Please always keep track of the disposal, and make sure the disposed camera cannot be accessed or used by any third party.

2. Introduction

ARTCAM-UV-WOM series is a series of ultraviolet cameras with high sensitivity to the wavelength band of 200 nm to 1200 nm.

ARTCAM-UV-WOM series adopt USB2.0 interface, so image data can be delivered to PC directly without a capture board. Also, this camera is equipped with an on board memory which avoid data missing during transfer.

3. Main Features

- UV Detection with High Sensitivity

The CMOS sensor can detect radiation invisible to human eyes and CMOS cameras in the wavelength range between 200 nm to 1200 nm band.

- USB2.0 Interface

Our cameras adopt USB2.0 interface, so the data can be delivered to PC directly and no capture board is needed.

- Software Development Kit

For customer who prefers to create their own image processing software or use our camera with other applications, SDK comes with our product.

4. The Product

- 1) Camera
- 2) USB Cable Type A-B connector cable, 3m approx.
- 3) Viewer software/Device Driver CD

<Options>

- 1) C Mount lens
- 2) 5m extension cable with USB2.0 repeater

5. Connect the Camera

5-1 How to connect a camera

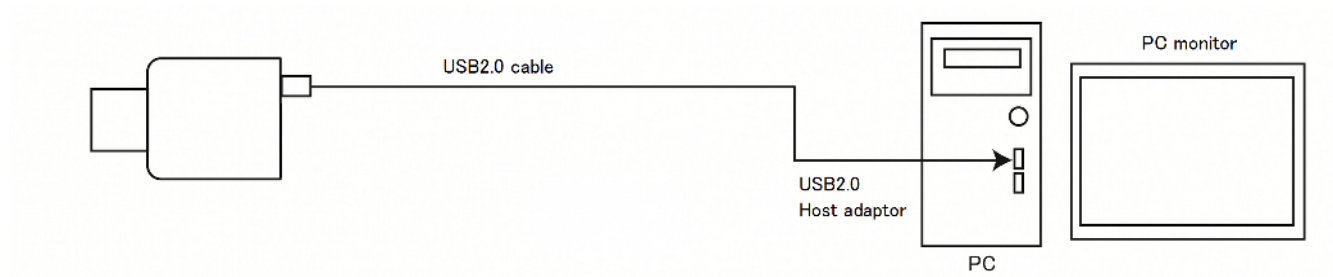

6. Specifications

6-1 Camera Specifications

| | ARTCAM-130UV-WOM | ARTCAM-092UV-WOM |
|------------------------|--|----------------------------|
| Sensor Type | CMOS Image Sensor | |
| Active Pixels | 1280(H)×1024(V) | 1280(H)×720(V) |
| Total Pixels | 1292(H)×1040(V) | 1292(H)×736(V) |
| Active Imager Size | 12.8(H)×10.2(V)mm 1" | 7.17(H)×4.03(V)mm 1/2" |
| Scan Mode | Progressive Scan | |
| Pixel Size | 10(H)×10(V)μm | 5.6(H)×5.6(V)μm |
| Detected Wavelength | 200 nm~1200 nm | |
| Shutter Type | Rolling Shutter | |
| Frame Rate | 27.7fps(8bit) / 14.2fps(12bit) | 40fps(8bit) / 20fps(12bit) |
| Shutter Speed | 1/31847~1.029s | 1/33898~0.967s |
| Detectivity | 39.57 V/lux-sec @550nm | 14.99 V/lux-sec @550nm |
| Gain | x3 ~ x24 | |
| A/D Resolution | 12bit | |
| Interface | USB2.0 Bulk transfer | |
| Synchronization System | Internal Synchronization | |
| Lens Mount | C Mount | |
| Power | DC5V | |
| Power Consumption | Under 2.5W | |
| Ambient Conditions | Operating Temperature/Humidity : 0~35°C/10~80%(Non condensing) Storage Temperature/Humidity : 0~60°C/10~95%(Non condensing) | |
| External Dimensions | 50.0(W)×47.0(H)×41.7(D)mm *Lens, tripod mount and cable not included. | |
| Weight | Approx.110g *Lens, tripod mount and cable not included. | |

·Depending on lens you use, our product might not reach the best condition and problems, such as the low resolution and lightness, might occur.

Please consult our sales representative for the recommended lenses.

6-2 Shutter Speed

Shutter speed can be changed on the standard viewer software ART-MEASURE.

The shutter speed is set directly on the sensor register.

Please refer to the following formulas for the real exposure time.

| Model | Formula |
|------------------|--|
| ARTCAM-130UV-WOM | Range : 1~32767 (1/31847~1.029sec) Exposure Time=2512 x Shutter Value x 0.0125 [μsec] |
| ARTCAM-092UV-WOM | Range : 1~32767 (1/33898~0.967sec) Exposure Time=2950 x Shutter Value x 0.01 [μsec] |

6-3. Global gain

Global gain (analog gain) can be configured with the standard viewer software or SDK.
The formulas for the setting value and gain are as follows.

| MODEL | METHOD |
|--|--|
| ARTCAM-130UV-WOM / ARTCAM-092UV-WOM | Setting range: 0 to 11 (x3 to x24) Setting value: between 0 and 6 -> Gain = value + 3 Setting value: between 7 and 11 -> Gain = (value - 3) * 3 Ex) When setting value is 0 -> 0 + 3 = 3 [x3 gain] When setting value is 11 -> (11 - 3) * 3 = 24 [x24 gain] |

6-4. Trigger Input (For 130UV-WOM)

ARTCAM-130UV-WOM has an external trigger input circuit insulated by a photo coupler.
Therefore, the camera can take pictures using external trigger.

Trigger Input Circuit

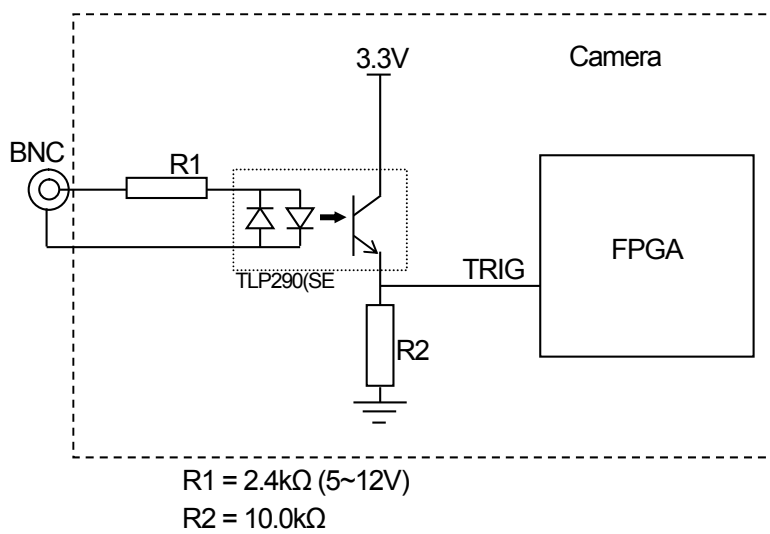

6-5. Trigger Timing Chart

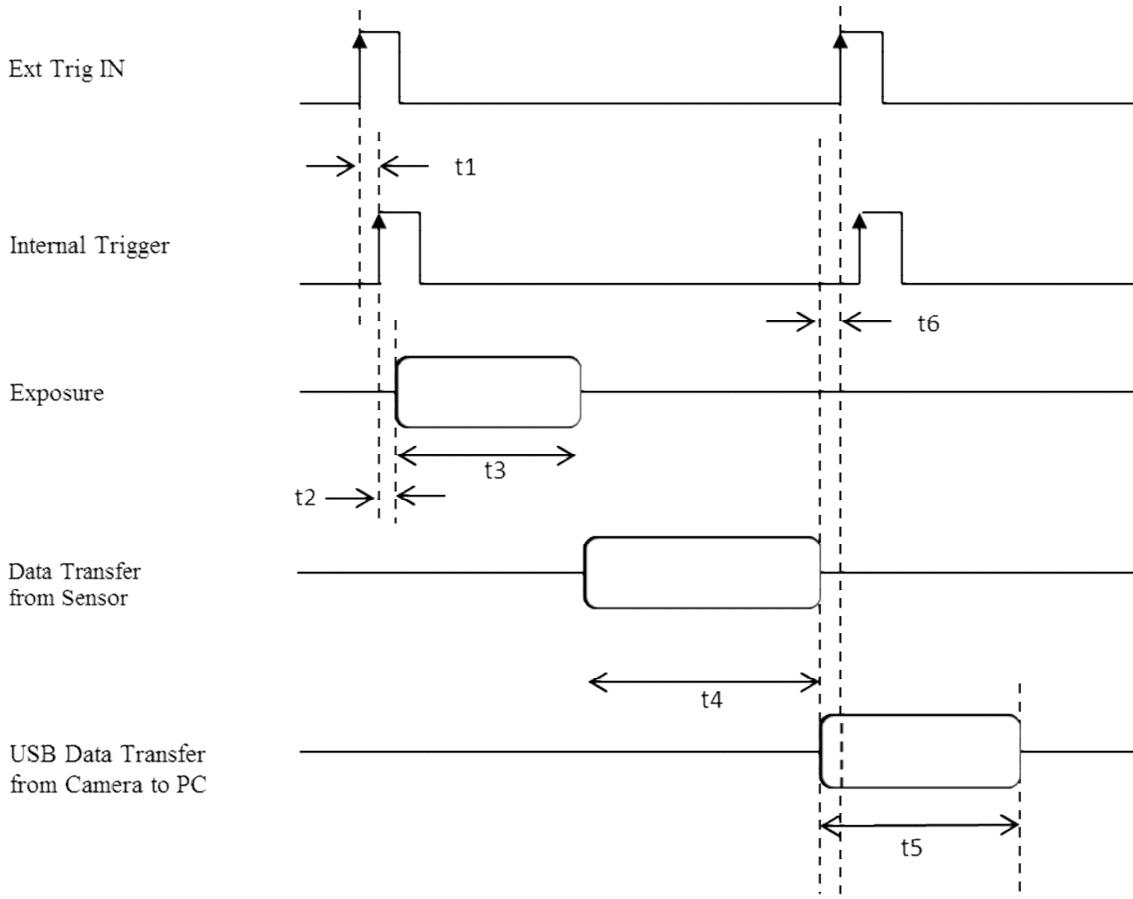

| NO. | ITEM | TIME |
|-----|----------------------------------|--|
| t1 | Photo-Coupler Delay | 1 micro second or less |
| t2 | Reset Time | 6 * 1H *1H = (1280 + 1232) * 1PCLK *1PCLK = 1/ 80000000 [sec] = 0.0125 [micro sec] |
| t3 | Exposure Time | Setting value of Exposure (Shutter speed) * 1H |
| t4 | Frame Transfer | The number of Row pixels * 1H |
| t5 | Image Transfer | About 33 [msec] (Subject to the BUS speed of USB) |
| t6 | Effective Trigger for next frame | 1H |

7. External Dimensions

7-1 ARTCAM-130UV-WOM / ARTCAM-092UV-WOM

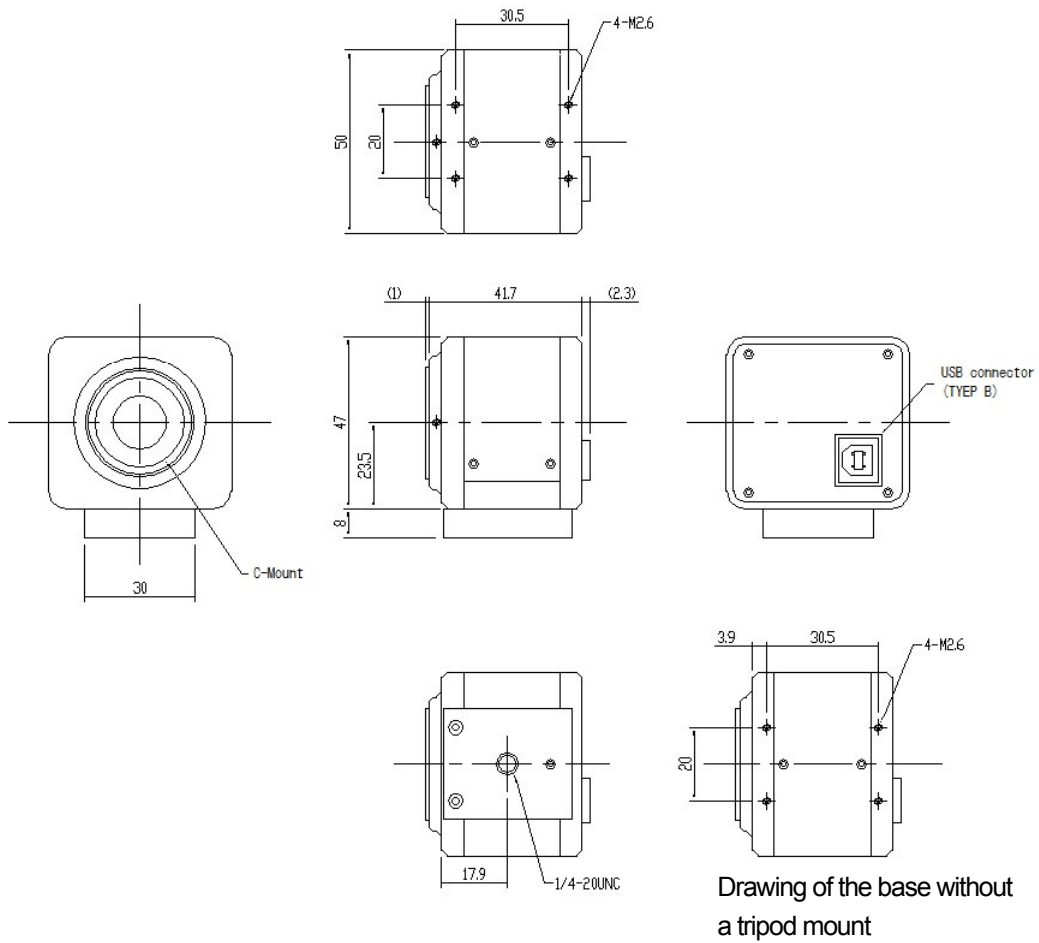

8. Spectral Sensitivity Characteristics

8-1 ARTCAM-130UV-WOM

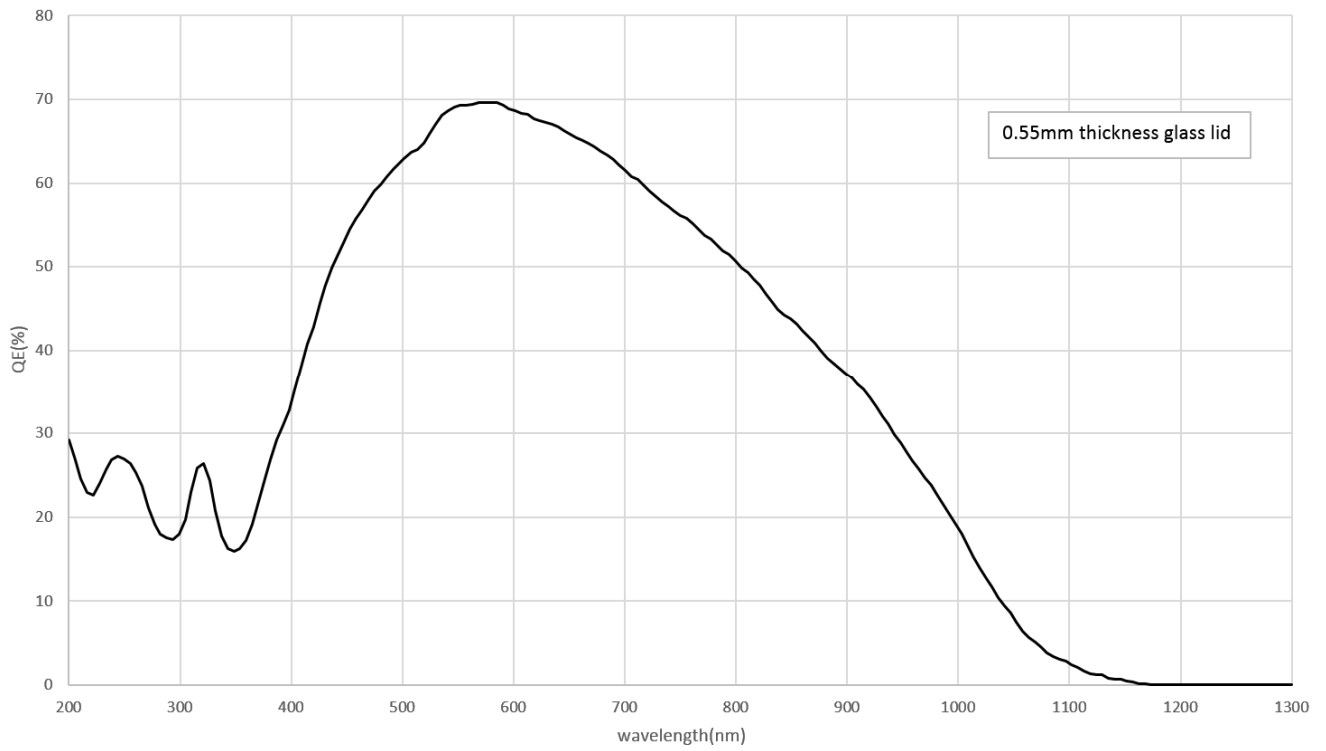

8-2 ARTCAM-092UV-WOM

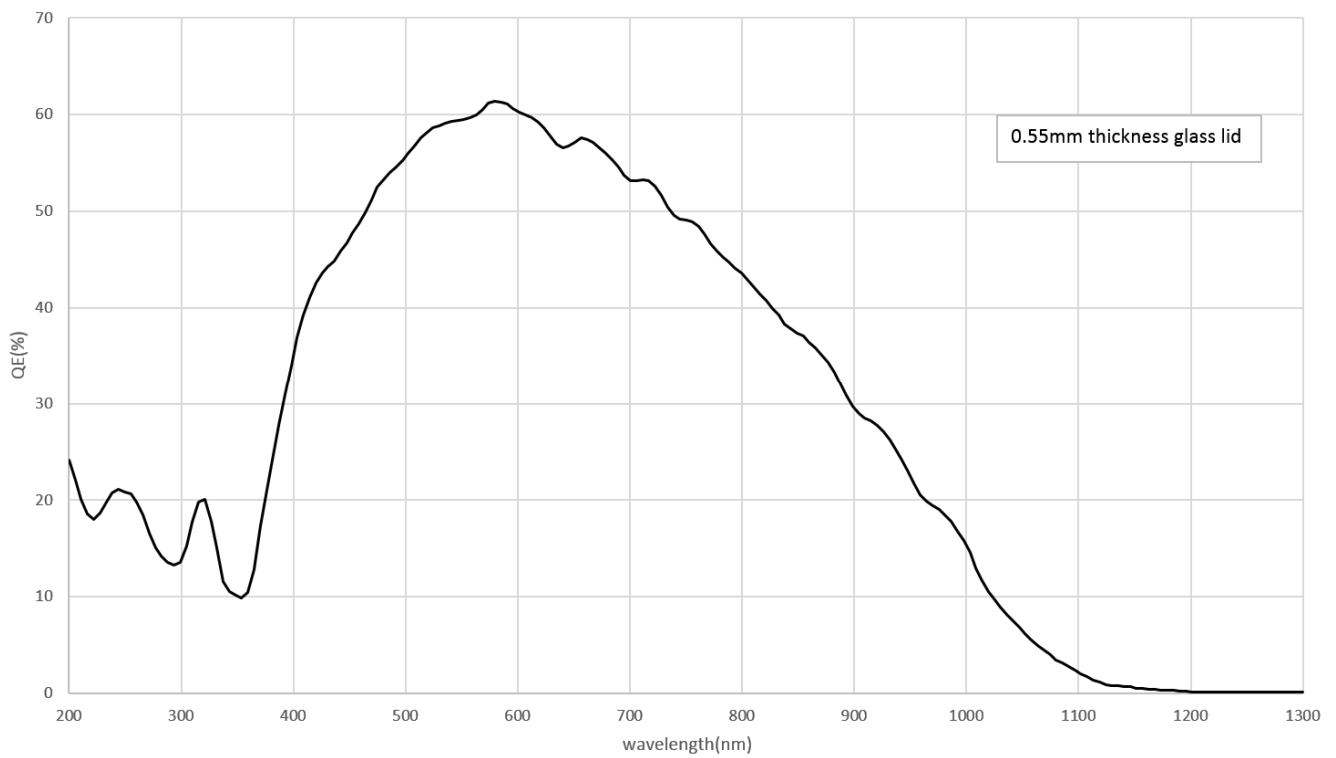

9. Recommended PC

9-1 Recommended System Requirements

●Host Controller

This camera is applicable to USB 2.0.

●CPU

The driver of this camera is applicable to computer architecture “x86” or “amd64”.

The specification of CPU effects directly the imaging process speed, therefore it is highly recommended to utilize a high-end CPU if possible.

●Memory

In the viewer software, there is a data buffer which can store 4 to 8 frames.

Therefore, it is necessary to keep spare space at least for 8 frames in the memory.

(For example, when using 1.3MP color camera, $1280 \times 1024 \times 3 \times 8$ [byte] = 30[MB] is necessary.)

It is highly recommended to keep enough memory space especially when using high resolution camera.

●OS

This camera is applicable only to the architecture of Windows NT (32bit/64bit).

Standard functions are confirmed with OS after Windows.

In addition, it is recommended to use Windows 10.



Caution

■Please refer the restrictions below when you use ARTCAM series.

(1) Recommended System Requirements

If the system specifications do not meet the requirements recommended above, it may be difficult to run at the maximum frame rate.

(2) Connection of Multiple USB Devices

When connecting multiple USB devices to one USB host controller, some USB device may fail to function stably depending on the specifications of the host controller.

(Problem of power supply, data transfer bandwidth, etc.)

To avoid power supply problem, it is recommended to use powered USB hub.

(3) USB2.0 Cable Extension

We cannot guarantee the functionality of the USB2.0 camera if the user adopts USB2.0 extension cables or repeaters which are not confirmed by us. With the extension cables or repeaters, the bandwidth of transfer may differ, and thus caused malfunctions such as a low frame rate or recognition failure on the camera.

What may cause the problem is that the regulation of the power lines becomes not enough, and so causes impedance mismatch on data signals.

*For the recommended extension cable, please contact our sales department.

(TEL: +81-3389-5488)

ARTRAY CO., LTD. Obtained ISO 9001: 2015 2018/9/17

1-17-5 Kouenjikota, Suginami-ku, Tokyo 166-0002 Japan

Tel: +81-3-3389-5488 Fax: +81-3-3389-5486

Email: sales@artray.us URL: www.artray.us