

USB2.0 NIR CMOS Camera

ARTCAM-XQE-Series

INSTRUCTION BOOKLET

1.3 M pixels	ARTCAM-130XQE-WOM
0.92 M pixels	ARTCAM-092XQE-WOM

ARTRAY

ARTRAY CO., LTD.

Contents

1. Attention	3
2. Introduction	6
3. Main Features	6
4. The Product	7
5. Connect the Camera	7
6. Specifications	8
7. External Dimensions	11
8. Recommended PC	12

1. Attention

■About this manual

1. Before using the camera, please read this manual thoroughly and use the camera properly.
2. Please keep this manual reachable and always refer to the contents when needed.
3. Please contact us if the manual is lost or damaged. We will provide a replacement. Our contact address is written in the end of this booklet.
4. We cannot guarantee the safety of improper uses of the camera.
5. For your safety, please follow the directions of this manual.
6. All contents are subject to change.
7. Images in this manual may have been simplified for easier comprehension.
8. Please contact us if you find any unclear points or mistakes in this manual. Our contact address is written in the end of this booklet.
9. Quoting, copying or altering some or all parts of the manual without our permission is prohibited.
10. We are not responsible for any losses or damages on your profits due to the use of our products.
11. Please understand that our oversea branches do not provide maintenance or repair services.

■About the Icons

To keep the safety of the user, other people and their properties, please pay attention to the following icons.



Warning

If the user fails to follow the instruction, serious injury or death may occur.



Caution

If the user fails to follow the instruction, physical injury on human or damages on hardware may occur.

■For Safe Use



Warning

●In following circumstances, please stop using the product and turn off the power immediately to prevent the risks of fires and electric shocks. If the product is defective, please contact us for repair or exchange. Our contact address is written in the end of this booklet. For your safety, please do not disassemble, modify or repair the camera on your own.

Please stop using the product and turn off the power immediately when:

- The camera emits smoke or gets extremely hot on the surface, or gives unusual smells or sounds.
 - Extraneous material or water gets into the product.
 - The product falls and gets damaged.
- Do not put the product on unstable surfaces. The product may fall and cause people hurt.



Caution

- Do not expose the product to steam or fumes to avoid electric shocks and fires.
- Do not leave the product in heated places such as near fire, inside of vehicles or under the direct sunlight. High temperature may cause damages to the camera, or even cause fires.
- Do not cover the product with cloths or other materials. The product may get extremely hot and the heat may cause deformations on the parts or even cause fires.
- Please avoid dropping or giving shock on the product as the product may be damaged.
- Do not touch the cable with a wet hand. Such action may cause electric shocks.
- When the camera is working, please avoid touching the surface of the camera for a long while. The surface temperature of the camera may cause burns.

■Other Notices

●Please do not use the camera under strong lights such as sun light for a long while. Also, please do not expose the camera under strong lights even when the product is not being used because the sensor might be damaged.

Maintenance

●Wipe the dirt on surface with soft cloth or tissue paper. Do not use alcohol, thinner or benzene to avoid damaging the surface paints.

Electro Magnetic Interference

●The camera may interference with electronic devices such as TV and radio. Please do not place the camera next to such equipment.

■Export Control

The Government of Japan controls military sensitive goods and technologies including relevant dual-use goods and technologies.

This product is a Catch-all Control item subject to the Foreign Exchange and Foreign Trade Act and its relevant legislations. Except for exporting to the 26 white countries designated in the Cabinet Order, export licenses are required if the products are going to be used for military use or if the end user of the product is related to all kinds of military activities. If your circumstances cause the need to apply export licenses, please notify us before you place orders. Also, please notify us in advance if the end users or purposes of use change after the purchase and thus cause the need to apply export licenses.

*The 26 white countries not under the UNSC Arms Embargo:

Argentina, Australia, Austria, Belgium, Bulgaria, Canada, Czech Republic, Denmark, Finland, France, Germany, Greece, Hungary, Ireland, Italy, Luxemburg, Netherlands, New Zealand, Norway, Poland, Portugal, Spain, Sweden, Switzerland, United Kingdom, and United States.

About the Japanese Security Export Controls, please refer to the webpage for Security Export Control Policy, the Ministry of Economy, Trade and Industry:

<http://www.meti.go.jp/policy/anpo/englishpage.html>

■Guarantee

To save the environment, we do not issue warranty in printed format. Instead, all records of the warranty periods, delivery dates and the customer information are well kept in our system.

For more details, please refer to the following link:

Hardware Warranty: http://www.artray.us/download/artray_warranty.pdf

●We do not guarantee the functions of this product or the descriptions on this manual to be completely adapted to the users' end applications or marketing purposes. We are also not held responsibility for any direct or indirect damages caused by our products under any circumstances.

●Please do not use this product for a task that require high reliability. This product is not manufactured to be used as medical, nuclear, aerospace, transportation equipment or equipment or that is highly related to human safety. We are not held responsibility for any damages on the users' property, equipment or personal safety caused by this product.

■Disposal

●To dispose this product, please return the camera to us. If you decide to dispose the camera without returning it to us, please follow related regulations and have the camera disposed as an industrial waste. Please always keep track of the disposal, and make sure the disposed camera cannot be accessed or used by any third party.

2. Introduction

ARTCAM-XQE-WOM series are NIR cameras which adopt a 1280 x 1024/ 1280 x 720 sensor. The cameras have a high sensitive spectral response from 400 nm to 1200 nm.

ARTCAM-XQE-WOM adopt USB2.0 interface, so image data can be delivered to PC directly without a capture board. Also, this camera is equipped with an on board memory which avoid data missing during transfer.

3. Main Features

- NIR Detection with High Sensitivity

The CMOS sensor can detect radiation invisible to human eyes and CCD/CMOS cameras in the wavelength range between 400 nm to 1200 nm band.

- USB2.0 Interface

Our cameras adopt USB2.0 interface, so the data can be delivered to PC directly and no capture board is needed.

- Software Development Kit

For customer who prefers to create their own image processing software or use our camera with other applications, SDK comes with our product.

4. The Product

- 1) Camera
- 2) USB Cable Type A-B connector cable, 3m approx.
- 3) Viewer software/Device Driver CD

<Options>

- 1) C Mount lens
- 2) 5m extension cable with USB2.0 repeater

5. Connect the Camera

5-1 How to connect a camera

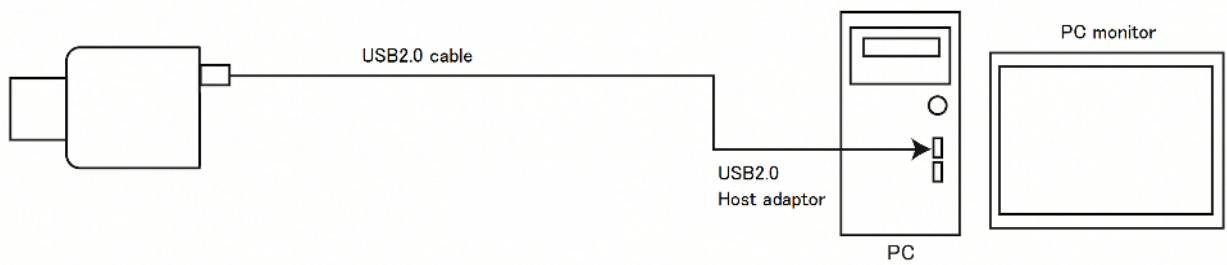

6. Specifications

6-1 Camera Specifications

	ARTCAM-130XQE-WOM	ARTCAM-092XQE-WOM
Sensor Type	CMOS Image Sensor	
Active Pixels	1280(H)×1024(V)	1280(H)×720(V)
Total Pixels	1292(H)×1040(V)	1292(H)×736(V)
Active Imager Size	12.8(H)×10.2(V)mm 1"	7.17(H)×4.03(V)mm 1/2"
Scan Mode	Progressive Scan	
Pixel Size	10(H)×10(V)μm	5.6(H)×5.6(V)μm
Detected Wavelength	400~1200nm	
Shutter Type	Rolling Shutter	
Frame Rate	27.7fps(8bit) / 14.2fps(12bit)	40fps
Shutter Speed	1/31847~1.029s	1/33898~0.967s
Detectivity	39.57 V/lux-sec @550nm	14.99 V/lux-sec @550nm
Gain	x3 ~ x24	
A/D Resolution	12bit	
Interface	USB2.0 Bulk transfer	
Synchronization System	Internal Synchronization	
Lens Mount	C Mount	
Power	DC5V	
Power Consumption	Under 2.5W	
Ambient Conditions	Operating Temperature/Humidity : 0~35°C/10~80%(Non condensing) Storage Temperature/Humidity : 0~60°C/10~95%(Non condensing)	
External Dimensions	50.0(W)×47.0(H)×41.7(D)mm *Lens, tripod, cable not included.	
Weight	Approx.110g *Lens, tripod, cable not included.	

· Depending on lens you use, our product might not reach the best condition and problems, such as the low resolution and lightness, might occur.

Please consult our sales representative for the recommended lenses.

6-2 Shutter Speed

Shutter speed can be changed on the standard viewer software ART-Viewer.

The shutter speed is set directly on the sensor register, so please refer to the following formulas for the real exposure time.

Model	Formula
ARTCAM-130XQE-WOM	Range : 1~32767 (1/31847~1.029sec) Exposure Time=2512 x Shutter Value x 0.0125 [μsec]
ARTCAM-092XQE-WOM	Range : 1~32767 (1/33898~0.967sec) Exposure Time=2950 x Shutter Value x 0.01 [μsec]

6-3. Global gain

Global gain can be configured with the standard viewer software or SDK.

The formulas for the setting value and gain are as follows.

Model	formula
ARTCAM-130XQE-WOM/ ARTCAM-092XQE-WOM	Setting range : 0 to 11 (x3 to x24) Setting value :between 0 and 6 -> Gain = value + 3 Setting value :between 7 and 11 -> Gain = (value - 3) * 3 Ex) When setting value is 0 -> 0 + 3 = 3 [x3 gain] When setting value is 11 -> (11 - 3) * 3 = 24 [x24 gain]

6-4. Trigger Input (For 130XQE-WOM)

ARTCAM-130XQE-WOM has an external trigger input circuit insulated by a photo coupler.

Therefore the camera can take pictures using external trigger.

Trigger Input Circuit

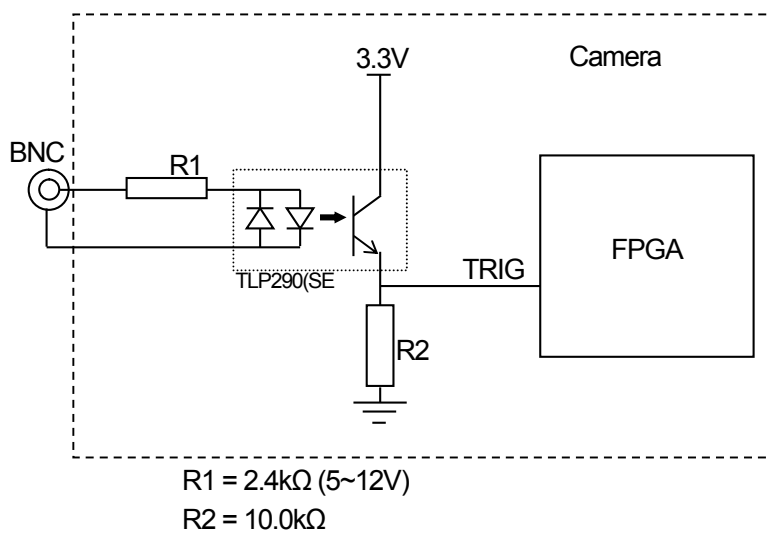

6-5. Trigger timing chart

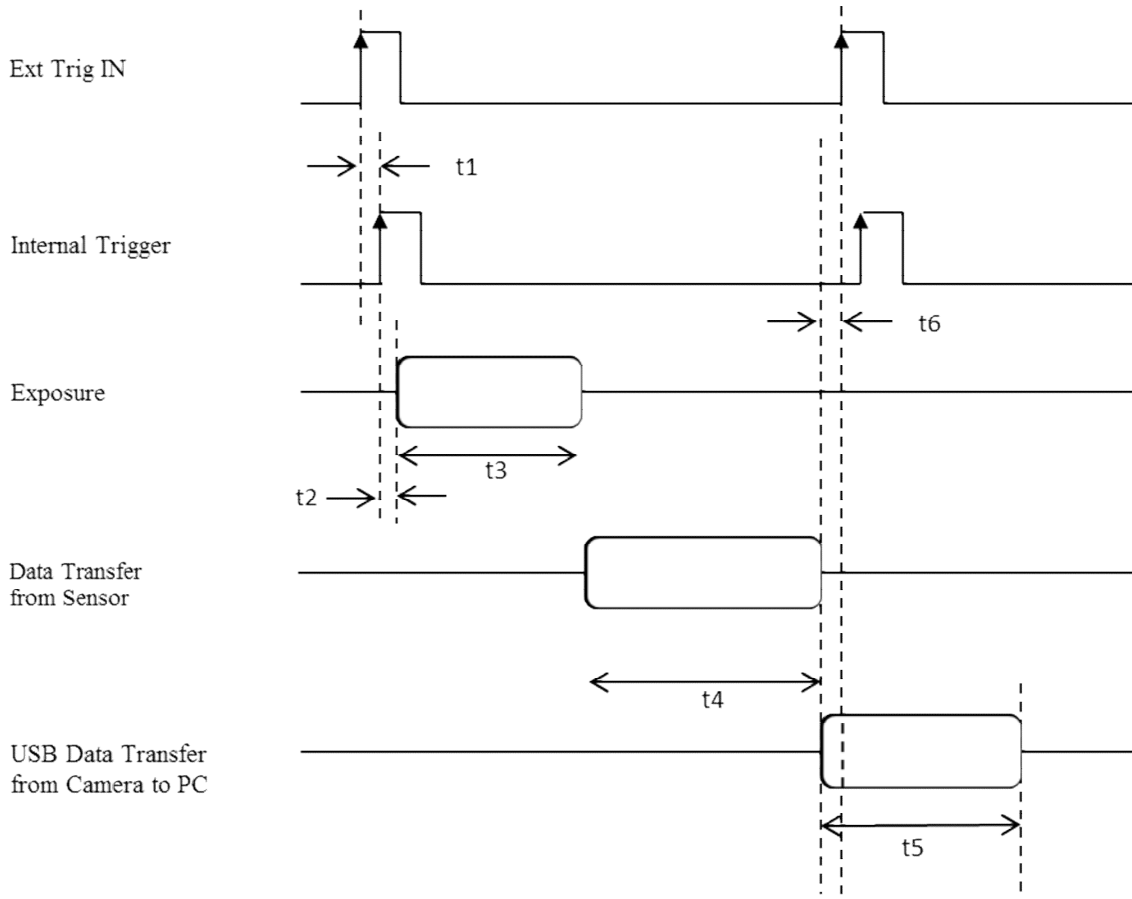

Number	Item	Time
t1	Photo-coupler Delay	Above 1 micro second
t2	Reset Time	$6 * 1H$ $\text{※}1H = (1280 + 1232) * 1PCLK$ $\text{※}1PCLK = 1/80000000[\text{sec}] = 0.0125[\text{micro sec}]$
t3	Exposure Time	Setting value of Exposure(Shutter speed) * 1H
t4	Frame Transfer	The number of Row pixels * 1H
t5	Image Transfer	About 33[msec] (Subject to the BUS speed of USB)
t6	Effective Trigger for next frame	1H

7. External Dimensions

7-1 ARTCAM-130XQE-WOM / ARTCAM-092XQE-WOM

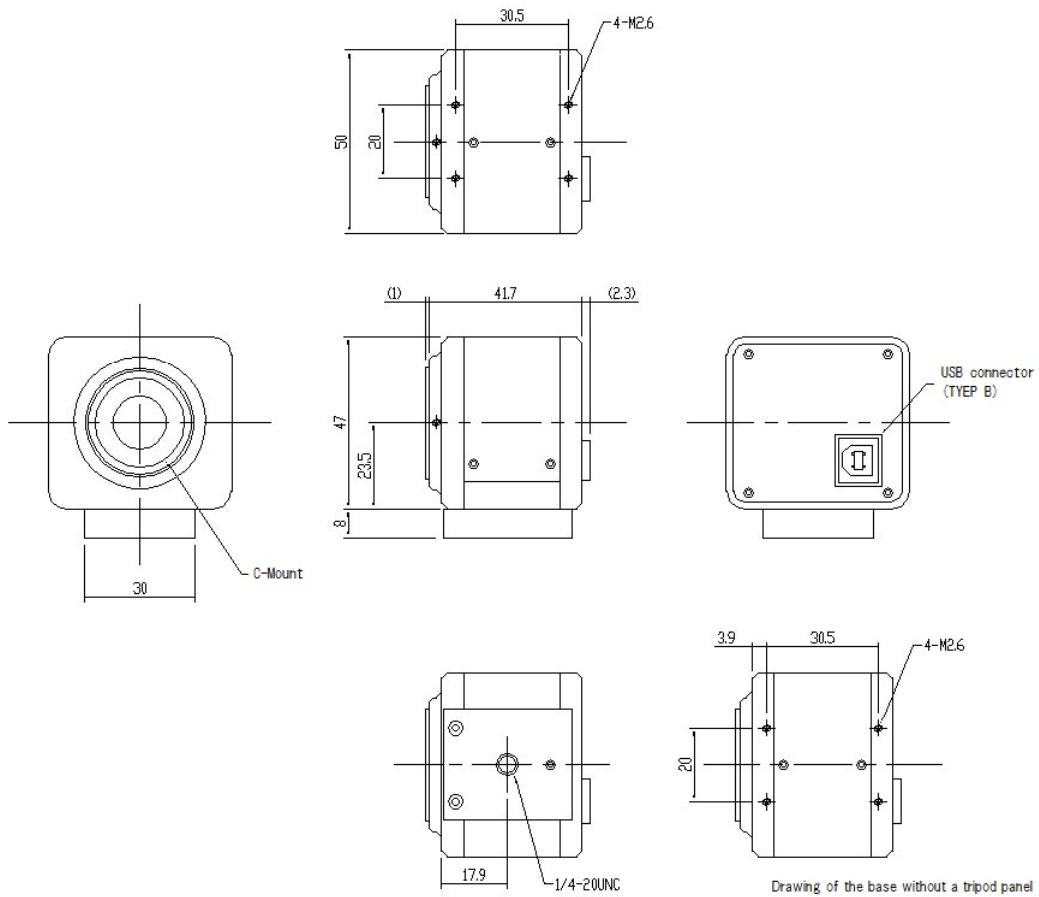

8. Recommended PC

8-1 Recommended System Requirements

- Intel chip set, Southbridge above ICH6
- CPU: Intel Core2duo 2.4GHz or higher
- Memory: \geq 512MB
- OS: \geq Windows XP

8-2 Minimum System Requirements

- USB2.0 Enhanced Host Controller
- CPU: Intel Pentium4 1.7GHz or higher
- Memory: \geq 256MB
- OS: \geq Windows XP



Caution

■Please refer to the restrictions below when you use ARTCAM.

(1) Recommended System Requirements

If the system specifications do not meet the requirements recommended above, especially the camera runs at 48Hz of clock frequency, it may be difficult to run at the maximum frame rate.

To make use of the specification of the camera, please prepare a PC with the specification above or better.

(2) Connection of Multiple USB Devices

Please be aware that PC may be short of power to supply if you connected multiple USB devices. It also depends on the specifications of the user's PC.

(3) Extension of USB2.0 cable

We cannot guarantee the functionality of the USB2.0 camera if the user adopts USB2.0 extension cables or repeaters which are not confirmed by us. With the extension cables or repeaters, the bandwidth of transfer may differ, and thus caused malfunctions such as a low frame rate or recognition failure on the camera.

What may cause the problem is that the regulation of the power lines becomes not enough, and so causes impedance mismatch on data signals.

*For the recommended extension cable, please contact our sales department. (TEL: +81-3-3389-5488)

ARTRAY CO., LTD. Obtained ISO 9001: 2015 2018/9/17

1-17-5 Kouenjikota, Suginami-ku, Tokyo 166-0002 Japan

Tel: +81-3-3389-5488 Fax: +81-3-3389-5486

Email: sales@artray.us URL: www.artray.us