

USB2.0 CCD CAMERA

ARTCAM-WOM Series

INSTRUCTION BOOKLET

0.3M pixels	ARTCAM-424KY-WOM Series
1.25M pixels	ARTCAM-445KY2-WOM Series
1.5 M pixels	ARTCAM-150P5-WOM Series
1.5 M pixels	ARTCAM-285CX-WOM Series
2.0 M pixels	ARTCAM-274KY-WOM Series
5.0 M pixels	ARTCAM-500P2-WOM Series
5.0 M pixels	ARTCAM-655KY-WOM Series

Contents

1. Attention.....	3
2. Introduction.....	6
3. Main Features.....	6
4. The Product.....	7
5. Connect the Camera.....	8
6. Specifications.....	9
7. External Dimensions.....	13
8. Spectral Sensitivity Characteristics.....	19
9. AD Conversion.....	26
10. Optional Functions.....	27
11. Recommended PC.....	29

1. Attention

■About this manual

1. Before using the camera, please read this manual thoroughly.
2. Please keep this manual reachable and always refer to the contents when needed.
3. Please contact us if the manual is lost or damaged. We will provide an replacement.
4. We cannot guarantee the safety of improper uses of the camera.
5. For your safety, please follow the directions of this manual.
6. All contents are subject to change.
7. Images in this manual may have been simplified to be easier comprehended.
8. Please contact us if you find any unclear points or mistakes in this manual.
9. Quoting, copying or altering some or all parts of the manual without our permission is prohibited.
10. We are not responsible for any lost or damages on your profits due to the use of our products.
11. Please understand that our oversea branches do not provide maintenance or repair services.

■About the Icons

To keep the safety of the user, other people and their properties, please pay attention to the following icons.



Warning

If the user fails to follow the instruction, physical injury on human or damages on hardware may occur.



Caution

If the user fails to follow the instruction, serious injury or death may occur.

■For Safe Use



Warning

●In following circumstances, please stop using the product and turn off the power immediately to prevent the risks of fires and electric shocks. If the product is defective, please contact us for repair or exchange. For your safety, please do not disassemble, modify or repair the camera on your own.

Please stop using the product and turn off the power immediately when:

- The product becomes smoky or gets extremely hot on the surface, or makes unusual smells or sounds.
- Foreign material or water gets into the product.
- The product falls and becomes damaged.

●Do not place the product on unstable surfaces. The product may be fallen and people may get hurt.



Caution

●Do not expose the product to steam or fumes to avoid electric shocks and fires.

●Do not leave the product in high temperature places such as inside of vehicles or under direct sunlight. High temperature may cause damages to the camera, or even cause fires.

●Do not cover the product with cloth or other materials. The product may get extremely hot and the heat may cause deformations on the parts or even cause fires.

●Please avoid dropping or shocking the product as the product may be damaged.

●Do not touch the cable with a wet hand. Such action may cause electric shocks.

●Please avoid continuously contacting the surface of the camera to your skin when the camera is being used. The surface temperature of the camera may cause burns.

■Other Notices

●Please do not use the camera under strong lights such as sun light for a long period. Also please do not expose the camera under strong lights even when the product is not being used because the sensor might be damaged.

Maintenance

● Wipe the dirt on surface with soft cloth or tissue paper. Do not use alcohol, thinner or benzene to avoid damaging the surface paints.

Electro Magnetic Interference

●The camera may interference with electronic devices such as TV and radio. Please do not place the camera next to such equipment.

■Export Control

The Government of Japan controls military sensitive goods and technologies including relevant dual-use goods and technologies.

This product is a Catch-all Control item subject to the Foreign Exchange and Foreign Trade Act and its relevant legislations. Except for exporting to the 27 white countries designated in the Cabinet Order, export licenses are required if the products are going to be used for military use or if the end user of the product is related to all kinds of military activities. If your circumstances cause the need to apply export licenses, please notify us before you place orders. Also, please notify us in advance if the end users or purposes of use change after the purchase and thus cause the need to apply export licenses.

*The 27 white countries not under the UNSC Arms Embargo:

Argentina, Australia, Austria, Belgium, Bulgaria, Canada, Czech Republic, Denmark, Finland, France, Germany, Greece, Hungary, Ireland, Italy, Republic of Korea, Luxemburg, Netherlands, New Zealand, Norway, Poland, Portugal, Spain, Sweden, Switzerland, United Kingdom, and United States

About the Japanese Security Export Controls, please refer to the webpage for Security Export Control Policy, The Ministry of Economy, Trade and Industry:

<http://www.meti.go.jp/policy/anpo/englishpage.html>

■Guarantee

To save the environment, we do not issue warranty in printed format. Instead, all records of the warranty periods, delivery dates and the customer information are well kept in our system.

For more details, please refer to the sites below:

Hardware Warranty : http://www.artray.us/download/artray_warranty.pdf

2. Introduction

ARTCAM-WOM Series is CCD cameras for industrial use.

This series adopt USB2.0 interface, so the data can be delivered to PC directly without a capture board.

Cameras are equipped with on board memory which avoid data missing during transfer.

We provide a variety including cased cameras, board cameras which can be easily incorporated to other equipment, and so on.

3. Main Features

- High Resolution, High Frame Rate

We provide high speed CCD cameras of a wide range of resolutions from 0.3 mega pixels to 5 mega pixels.

- USB2.0 Interface

Our cameras adopt USB2.0 interface, so the data can be delivered to PC directly and no capture board is needed.

- Small and Light

Our cameras are small and light, thus can be easily installed according to your desires.

Also, the board type camera with small type board lens is easy to be incorporated with other machines.

- Varieties to Your Needs

We provide a variety including cased cameras, board type cameras, C-Mount board type cameras.

Also, we provide color and monochrome models to meet customers' needs.

- Bounded Viewer Software

We provide the Viewer Software - ART-Viewer (Windows XP/Vista/7).

With this software, users can easily preview, save images and change camera settings.

- 2D Measurement & Filing Software(Optional)

Useful 2D measuring functions are available with the optional 2D Measuring & Filing Software - ART-MEASURE.

- Recording Software(Optional)

The optional recording software - ART-REC allows the user to save movies in AVI format.

- Software Development Kit(Optional)

For customer who prefers to create their own image processing software or use our camera with other applications, we provide SDK upon requests.

4. The Product

1) Camera

2) USB Cable Type A-B connector cable, 3m approx.

*1 A USB cable with auxiliary power supply is attached for ARTCAM-424KY-WOM/ARTCAM-655KY-WOM series and customized model of external power supply is also available.

*2 For open frame type and model without USB connector, a Type A- connector of 3m will be attached.

3) Introduction Booklet

4) Viewer software/Device Driver CD

<Options>

1) C Mount lens

2) 2 Measurement & Filing Software [ART-MEASURE]

3) Recording Software [ART-REC]

4) Software Development Kit [ARTCCM-SDK]

5) 5m extension cable with USB2.0 repeater

5. Connect the Camera

5-1 How to connect a camera

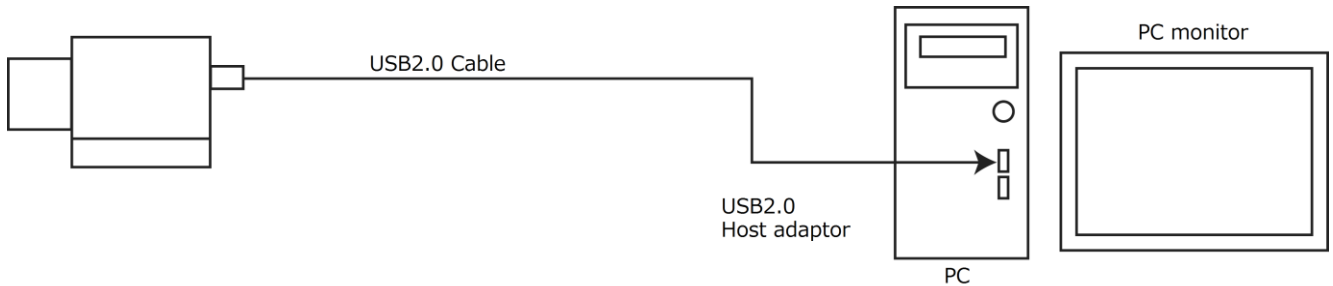

5-2 Shutter Speed

Shutter speed can be changed on the standard viewer software ART-Viewer.

The shutter speed is set directly on the sensor register, so please refer to the following formulas for the real exposure time.

Model	Method
424KY-WOM Series	Range : 1~525(Exposure Time : 1/96332~1/100 sec) $\text{Exposure Time} = ((525 - \text{Shutter Value}) \times 780) + 425 \times 0.0244 \quad [\mu\text{sec}]$ *at 40.94MHz
445KY2-WOM Series	Range : 2~1003(Exposure Time : 1/94488~1/22.47 sec) $\text{Exposure Time} = (((1003 - \text{Shutter Value}) \times 1600) + 381) \times 0.0278 \quad [\mu\text{sec}]$ *at 36MHz
150P5-WOM Series	Range : 7~1074(Exposure Time : 1/58824~1/12.5 sec) $\text{Exposure Time} = ((1074 - \text{Shutter Value}) \times 1790 + 424) \times 0.042 \quad [\mu\text{sec}]$ *at 24MHz
285CX-WOM Series	Range : 3~1070(Exposure Time : 1/39152~1/12.6 sec) $\text{Exposure Time} = ((1070 - \text{Shutter Value}) \times 1790 + 613) \times 0.042 \quad [\mu\text{sec}]$ *at 24MHz
274KY-WOM Series	Range : 2~1252(Exposure Time : 1/47493~1/15 sec) $\text{Exposure Time} = (((1252 - \text{Shutter Value}) \times 1920) + 758) \times 0.0278 \quad [\mu\text{sec}]$ *at 36MHz
500P2-WOM Series	Range : 1~1014(Exposure Time : 1/8293~1/4 sec) $\text{Exposure Time} = (\text{Shutter Value} \times 2894) \times 0.042 \quad [\mu\text{sec}]$ *Only when the shutter speed is set as 1014, exposure time will become $2028 \times 2894 \times 0.042 \quad [\mu\text{sec}]$ *at 24MHz
655KY-WOM Series	Range : 2~2078(Exposure Time : 1/12531~1/6 sec) $\text{Exposure Time} = (2079 - \text{Shutter Value}) \times 3192 \times 0.025 \quad [\mu\text{sec}]$ *at 40MHz

5-3 Operation clock settings

5-3-1 ARTCAM-150P5-WOM series

Users can switch the operation clock between 24MHz / 12MHz with the standard viewer software or SDK.

*40MHz may also be supported. For further details, please contact our sales representatives.

5-3-2 ARTCAM-285CX-WOM series

Users can switch the operation clock between 40MHz / 24MHz / 12MHz with the standard viewer software or SDK.

6. Specifications

6-1 Color Model

	ARTCAM- 424KY-WOM 424KY-WOM-OP 424KY-WOM-OP-CM	ARTCAM- 445KY2-WOM 445KY2-WOM-OP 445KY2-WOM-OP-CM	ARTCAM- 150P5-WOM 150P5-WOM-OP 150P5-WOM-OP-CM	ARTCAM- 285CX-WOM 285CX-WOM-OP-CM
Sensor Type	CCD Color Image Sensor			
Total Number Of Pixels	692(H)×504(V)	1348(H)×976(V)	1434(H)×1050(V)	1434(H)×1050(V)
Number Of Effective Pixels	659(H)×494(V)	1296(H)×966(V)	1392(H)×1040(V)	1392(H)×1040(V)
Resolution	656(H)×494(V)	1280(H)×960(V)	1360(H)×1024(V)	1360(H)×1024(V)
Active Imager Size	4.88(H)×3.66(V)mm 1/3"	4.86(H)×3.62(V)mm 1/3"	6.47(H)×4.83(V)mm 1/2"	8.98(H)×6.71(V)mm 2/3"
Scan Mode	Progressive Scan			
Pixel Size	7.4(H)×7.4(V)μm	3.75(H)×3.75(V)μm	4.65(H)×4.65(V)μm	6.45(H)×6.45(V)μm
Shutter Type	Global Shutter			
Color Filter Array	RGB Bayer Pattern			
Frame Rate	100fps	22fps	12fps	12.6fps
Shutter Speed	1/96332~1/100	1/94988~1/22.47s	1/58824~1/12.5s	1/39152~1/12.6s
Interface	USB2.0 Bulk Transfer			
Synchronization System	Internal Synchronization			
Lens Mount	C Mount (424KY-WOM, 424KY-WOM-OP-CM) Board lens Mount M12 P0.5 (424KY-WOM-OP)	C Mount (445KY2-WOM, 445KY2-WOM-OP-CM) Board lens Mount M12 P0.5(445KY2-WOM-OP)	C Mount (150P5-WOM, 150P5-WOM-OP-CM) Board lens Mount M12 P0.5 (150P5-WOM-OP)	C Mount (285CX-WOM, 285CX-WOM-OP-CM)
Power	DC5V(Supplied by USB port)			
Power Consumption	Under Approx.3W	Under Approx.2W		
Ambient Conditions	Operating Temperature/Humidity : 0~35°C/10~80%(Non condensing)			
External Dimensions	50(W)×47(H)×59.6(D)mm (424KY-WOM) 43.5(W)×43.5(H)×41.4(D)mm (424KY-WOM-OP) 50(W)×47(H)×43.8(D)mm (424KY-WOM-OP-CM) *Lens and tripod not included	50(W)×47(H)×49.7(D)mm (445KY2-WOM) 43.5(W)×43.5(H)×33.3(D)mm (445KY2-WOM-OP) 50(W)×47(H)×36.7(D)mm (445KY2-WOM-OP-CM) *Lens and tripod not included	50(W)×47(H)×49.7(D)mm (150P5-WOM) 43.5(W)×43.5(H)×33.3(D)mm (150P5-WOM-OP) 50(W)×47(H)×36.7(D)mm (150P5-WOM-OP-CM) *Lens and tripod not included	50(W)×47(H)×49.7(D)mm (285CX-WOM) 50(W)×47(H)×36.7(D)mm (285CX-WOM-OP-CM) *Lens and tripod not included
Weight	Approx.150g(424KY-WOM) Approx.70g(424KY-WOM-OP) Approx.110g(424KY-WOM-OP-CM) *Lens, tripod and cable not included	Approx.120g(445KY2-WOM) Approx.50g(445KY2-WOM-OP) Approx.80g(445KY2-WOM-OP-CM) *Lens, tripod and cable not included	Approx.120g(150P5-WOM) Approx.50g(150P5-WOM-OP) Approx.80g(150P5-WOM-OP-CM) *Lens, tripod and cable not included	Approx.120g(285CX-WOM) Approx.80g(285CX-WOM-OP-CM) *Lens, tripod and cable not included

6-2 Color Model

	ARTCAM- 274KY-WOM 274KY-WOM-OP 274KY-WOM-OP-CM	ARTCAM- 500P II -WOM 500P II -WOM-OP-CM	ARTCAM- 655KY-WOM 655KY-WOM-OP-CM
Sensor Type	CCD Color Image Sensor		
Total Number Of Pixels	1688(H)×1248(V)	2658(H)×1970(V)	2536(H)×2068(V)
Number Of Effective Pixels	1628(H)×1236(V)	2588(H)×1960(V)	2456(H)×2058(V)
Resolution	1600(H)×1200(V)	2560(H)×1920(V)	2456(H)×2058(V)
Active Imager Size	7.16(H)×5.44(V)mm 1/1.8"	8.80(H)×6.66(V)mm 2/3"	8.47(H)×7.10(V)mm 2/3"
Scan Mode	Progressive Scan	Interlace	Progressive Scan
Pixel Size	4.4(H)×4.4(V)μm	3.4(H)×3.4(V)μm	3.45(H)×3.45(V)μm
Shutter Type	Global Shutter		
Color Filter Array	RGB Bayer Pattern		
Frame Rate	15fps	4fps	6.1fps
Shutter Speed	1/47493~1/15s	1/8293~1/4s	1/12531~1/6s
Interface	USB2.0 Bulk Transfer		
Synchronization System	Internal Synchronization		
Lens Mount	C Mount (274KY-WOM, 274KY-WOM-OP-CM) Board lens Mount M12 P0.5 (274KY-WOM-OP)	C Mount (500P II -WOM, 500P II -WOM-OP-CM)	C Mount (655KY-WOM, 655KY-WOM-OP-CM)
Power	DC5V(Supplied by USB port)		
Power Consumption	Under Approx.2W		Under Approx.3W
Ambient Conditions	Operating Temperature/Humidity : 0~35°C/10~80%(Non condensing)		
External Dimensions	50(W)×47(H)×49.7(D)mm (274KY-WOM) 43.5(W)×43.5(H)×33.3(D)mm (274KY-WOM-OP) 50(W)×47(H)×36.7(D)mm (274KY-WOM-OP-CM) *Lens and tripod not included	50(W)×47(H)×49.7(D)mm (500P II -WOM) 50(W)×47(H)×36.7(D)mm (500P II -WOM-OP-CM) *Lens and tripod not included	50(W)×47(H)×59.6(D)mm (655KY-WOM) 50(W)×47(H)×43.8(D)mm (655KY-WOM-OP-CM) *Lens and tripod not included
Weight	Approx.120g(274KY-WOM) Approx.50g(274KY-WOM-OP) Approx.80g(274KY-WOM-OP-CM) *Lens, tripod and cable not included	Approx.120g(500P II -WOM) Approx.80g(500P II -WOM-OP-CM) *Lens, tripod and cable not included	Approx.150g(655KY-WOM) Approx.110g(655KY-WOM-OP-CM) *Lens, tripod and cable not included

6-3 Monochrome Model

	ARTCAM- 424KY-BW-WOM 424KY-BW-WOM-OP 424KY-BW-WOM-OP-CM	ARTCAM- 445KY2-BW-WOM 445KY2-BW-WOM-OP 445KY2-BW-WOM-OP-CM	ARTCAM- 150P5-BW-WOM 150P5-BW-WOM-OP 150P5-BW-WOM-OP-CM	ARTCAM- 285CX-BW-WOM 285CX-BW-WOM-OP-CM
Sensor Type	CCD Monochrome Image Sensor			
Total Number Of Pixels	692(H)×504(V)	1348(H)×976(V)	1434(H)×1050(V)	1434(H)×1050(V)
Number Of Effective Pixels	659(H)×494(V)	1296(H)×966(V)	1392(H)×1040(V)	1392(H)×1040(V)
Resolution	656(H)×494(V)	1280(H)×960(V)	1360(H)×1024(V)	1360(H)×1024(V)
Active Imager Size	4.88(H)×3.66(V)mm 1/3"	4.86(H)×3.62(V)mm 1/3"	6.47(H)×4.83(V)mm 1/2"	8.98(H)×6.71(V)mm 2/3"
Scan Mode	Progressive Scan			
Pixel Size	7.4(H)×7.4(V)μm	3.75(H)×3.75(V)μm	4.65(H)×4.65(V)μm	6.45(H)×6.45(V)μm
Shutter Type	Global Shutter			
Frame Rate	100fps	22fps	12fps	12.6fps
Shutter Speed	1/96332~1/100s	1/94988~1/22.47s	1/58824~1/12.5s	1/39152~1/12.6s
Interface	USB2.0 Bulk Transfer			
Synchronization System	Internal Synchronization			
Lens Mount	C Mount (424KY-BW-WOM, 424KY-BW-WOM-OP-CM) Board lens Mount M12 P0.5(424KY-BW-WOM-OP)	C Mount (445KY2-BW-WOM, 445KY2-BW-WOM-OP-CM) Board lens Mount M12 P0.5(445KY2-BW-WOM-OP)	C Mount (150P5-BW-WOM, 150P5-BW-WOM-OP-CM) Board lens Mount M12 P0.5 (150P5-BW-WOM-OP)	C Mount (285CX-BW-WOM, 285CX-BW-WOM-OP-CM)
Power	DC5V(Supplied by USB port)			
Power Consumption	Under Approx.3W	Under Approx.2W		
Ambient Conditions	Operating Temperature/Humidity : 0~35°C/10~80%(Non condensing)			
External Dimensions	50(W)×47(H)×59.6(D)mm (424KY-BW-WOM) 43.5(W)×43.5(H)×41.4(D)mm (424KY-BW-WOM-OP) 50(W)×47(H)×43.8(D)mm (424KY-BW-WOM-OP-CM) *Lens and tripod not included	50(W)×47(H)×49.7(D)mm (445KY2-BW-WOM) 43.5(W)×43.5(H)×33.3(D)mm (445KY2-BW-WOM-OP) 50(W)×47(H)×36.7(D)mm (445KY2-BW-WOM-OP-CM) *Lens and tripod not included	50(W)×47(H)×49.7(D)mm (150P5-BW-WOM) 43.5(W)×43.5(H)×33.3(D)mm (150P5-BW-WOM-OP) 50(W)×47(H)×36.7(D)mm (150P5-BW-WOM-OP-CM) *Lens and tripod not included	50(W)×47(H)×49.7(D)mm (285CX-BW-WOM) 50(W)×47(H)×36.7(D)mm (285CX-BW-WOM-OP-CM) *Lens and tripod not included
Weight	Approx.150g(424KY-BW-WOM) Approx.70g(424KY-BW-WOM-OP) Approx.110g(424KY-BW-WOM-OP-CM) *Lens, tripod and cable not included	Approx.120g(445KY2-BW-WOM) Approx.50g(445KY2-BW-WOM-OP) Approx.80g(445KY2-BW-WOM-OP-CM) *Lens, tripod and cable not included	Approx.120g(150P5-BW-WOM) Approx.50g(150P5-BW-WOM-OP) Approx.80g(150P5-BW-WOM-OP-CM) *Lens, tripod and cable not included	Approx.120g(285CX-BW-WOM) Approx.80g(285CX-BW-WOM-OP-CM) *Lens, tripod and cable not included

6-4 Monochrome Model

	ARTCAM- 274KY-BW-WOM 274KY-BW-WOM-OP 274KY-BW-WOM-OP-CM	ARTCAM- 655KY-BW-WOM 655KY-BW-WOM-OP-CM
Sensor Type	CCD Monochrome Image Sensor	
Total Number Of Pixels	1688(H)×1248(V)	2536(H)×2068(V)
Number Of Effective Pixels	1628(H)×1236(V)	2456(H)×2058(V)
Resolution	1600(H)×1200(V)	2456(H)×2058(V)
Active Imager Size	7.16(H)×5.44(V)mm 1/1.8"	8.47(H)×7.10(V)mm 2/3"
Scan Mode	Progressive Scan	
Pixel Size	4.4(H)×4.4(V)μm	3.45(H)×3.45(V)μm
Shutter Type	Global Shutter	
Frame Rate	15fps	6.1fps
Shutter Speed	1/47493~1/15s	1/12531~1/6s
Interface	USB2.0 Bulk Transfer	
Synchronization System	Internal Synchronization	
Lens Mount	C Mount (274KY-BW-WOM、274KY-BW-WOM-OP-CM) Board lens Mount M12 P0.5 (274KY-BW-WOM-OP)	C Mount (655KY-BW-WOM、655KY-BW-WOM-OP-CM)
Power	DC5V(Supplied by USB port)	
Power Consumption	Under Approx.2W	Under Approx.3W
Ambient Conditions	Operating Temperature/Humidity : 0~35°C/10~80%(Non condensing)	
External Dimensions	50(W)×47(H)×49.7(D)mm (274KY-BW-WOM) 43.5(W)×43.5(H)×33.3(D)mm (274KY-BW-WOM-OP) 50(W)×47(H)×36.7(D)mm (274KY-BW-WOM-OP-CM) *Lens and tripod not included	50(W)×47(H)×59.6(D)mm (655KY-BW-WOM) 50(W)×47(H)×43.8(D)mm (655KY-BW-WOM-OP-CM) *Lens and tripod not included
Weight	Approx.120g(274KY-BW-WOM) Approx.50g(274KY-BW-WOM-OP) Approx.80g(274KY-BW-WOM-OP-CM) *Lens, tripod and cable not included	Approx.150g(655KY-BW-WOM) Approx.110g(655KY-BW-WOM-OP-CM) *Lens, tripod and cable not included

7. External Dimensions

7-1 C-MOUNT, CASED, USB CABLE TYPE

ARTCAM-445KY2-WOM / 445KY2-BW-WOM

ARTCAM-150P5-WOM / 150P5-BW-WOM

ARTCAM-285CX-WOM / 285CX-BW-WOM

ARTCAM-274KY-WOM / 274KY-BW-WOM

ARTCAM-500P II-WOM

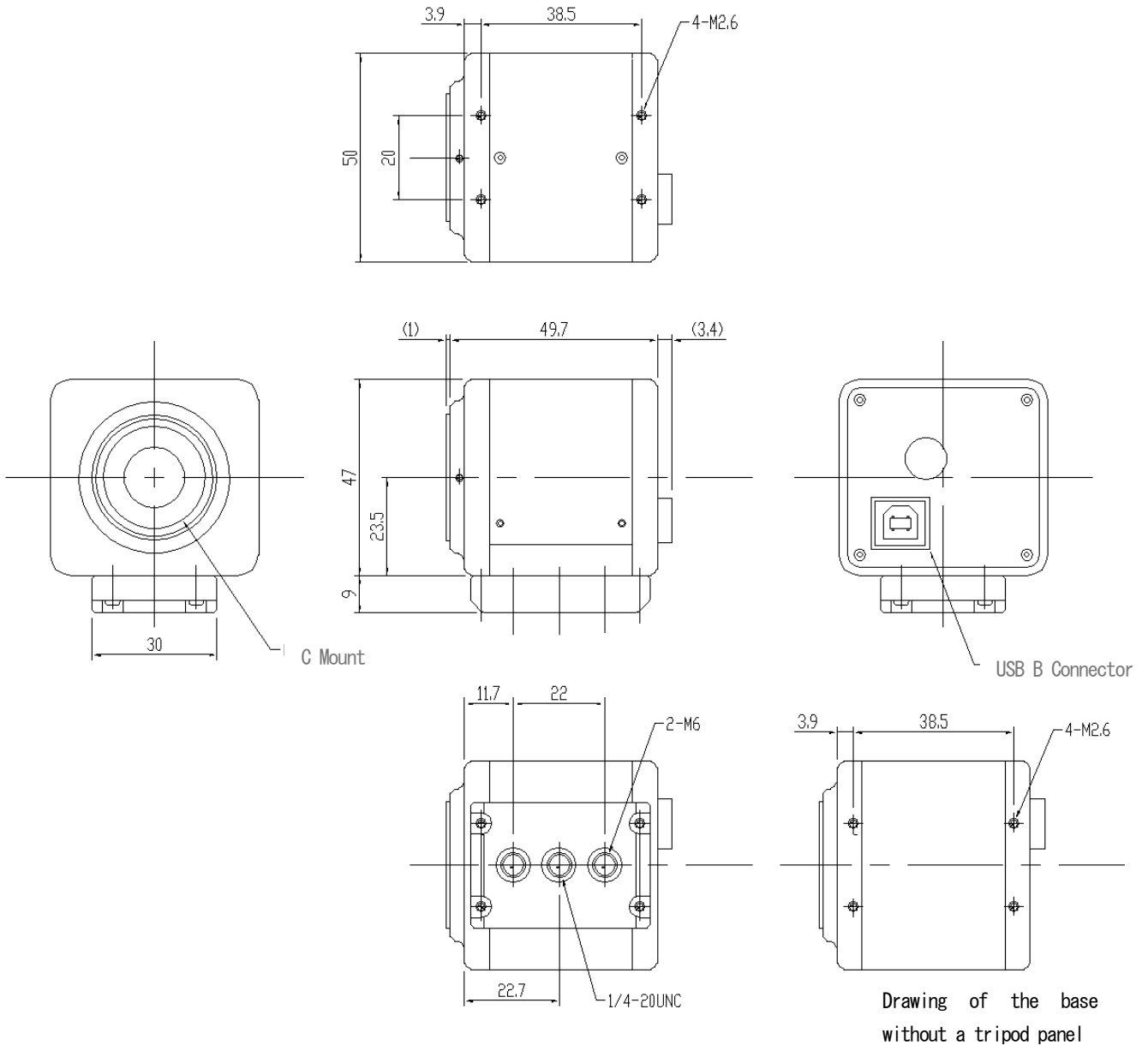

7-2 C-MOUNT, CASED, USB CABLE TYPE
 ARTCAM-424KY-WOM / 424KY-BW-WOM
 ARTCAM-655KY-WOM / 655KY-BW-WOM

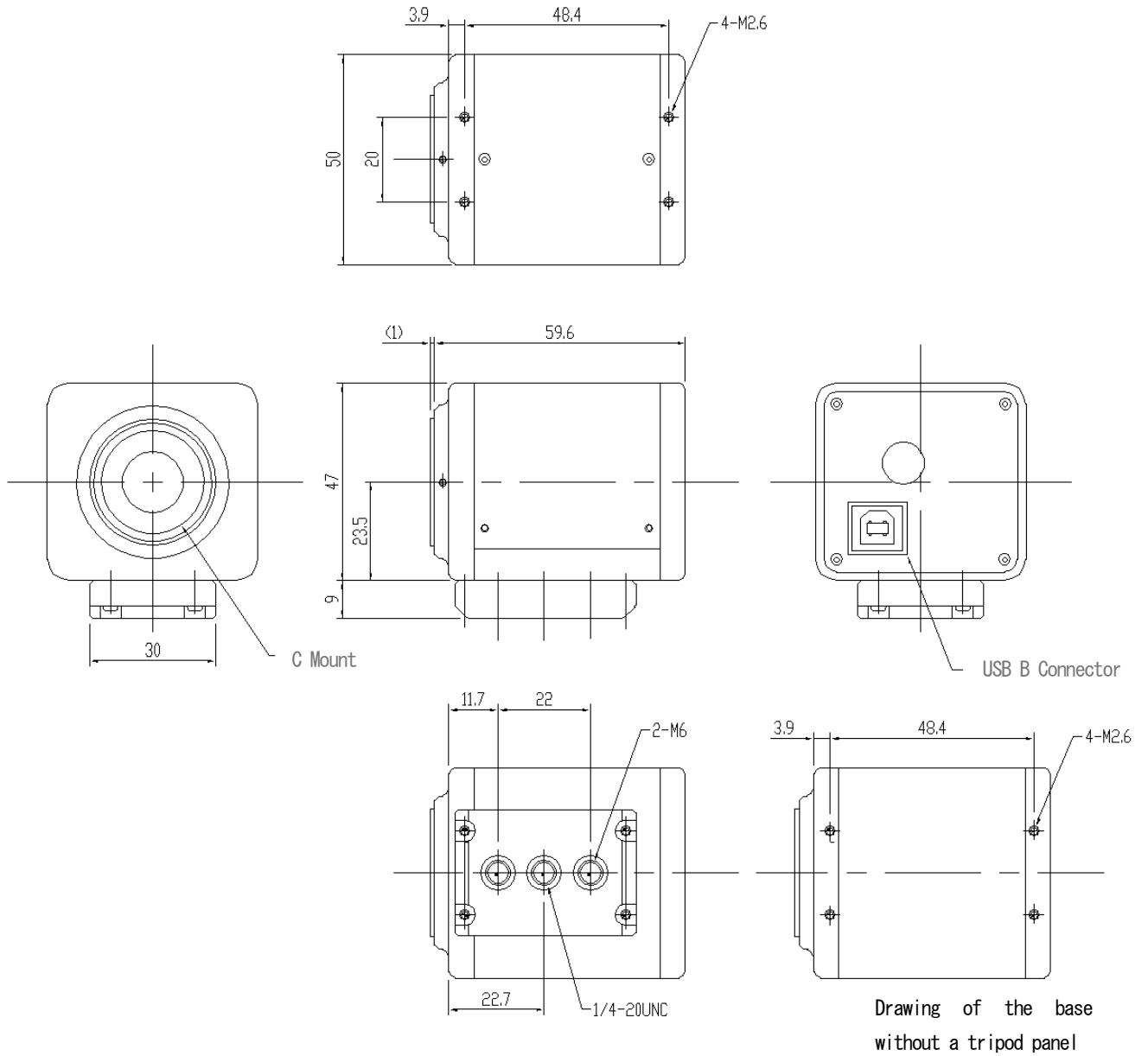

7-3 BOARD LENS, BOARD TYPE

ARTCAM-445KY2-WOM-OP / 445KY2-BW-WOM-OP

ARTCAM-150P5-WOM-OP / 150P5-BW-WOM-OP

ARTCAM-274KY-WOM-OP / 274KY-BW-WOM-OP

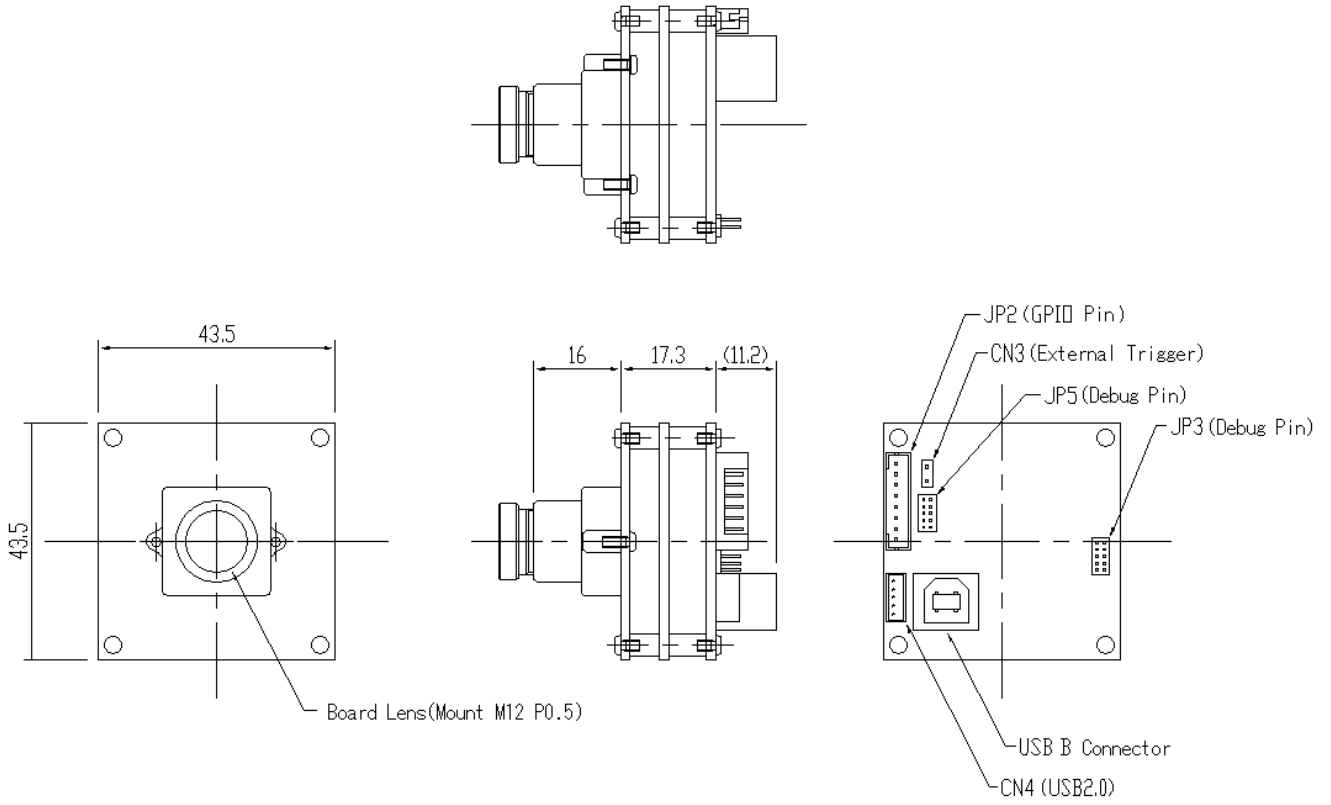

7-4 BOARD LENS, BOARD TYPE
 ARTCAM-424KY-WOM-OP / 424KY-BW-WOM-OP

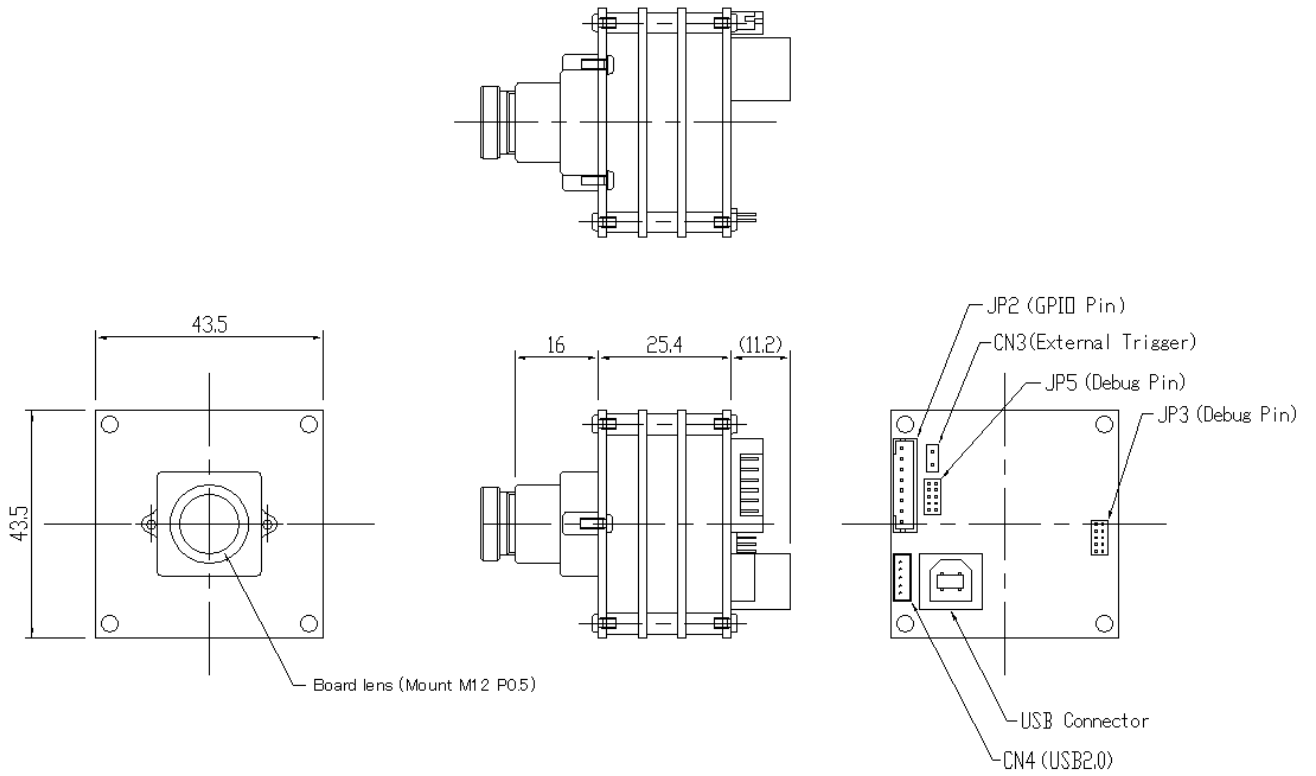

7-5 C-MOUNT, BOARD TYPE

ARTCAM-445KY2-WOM-OP-CM / 445KY2-BW-WOM-OP-CM

ARTCAM-150P5-WOM-OP-CM / 150P5-BW-WOM-OP-CM

ARTCAM-285CX-WOM-OP-CM / 285CX-BW-WOM-OP-CM

ARTCAM-274KY-WOM-OP-CM / 274KY-BW-WOM-OP-CM

ARTCAM-500P II -WOM-OP-CM

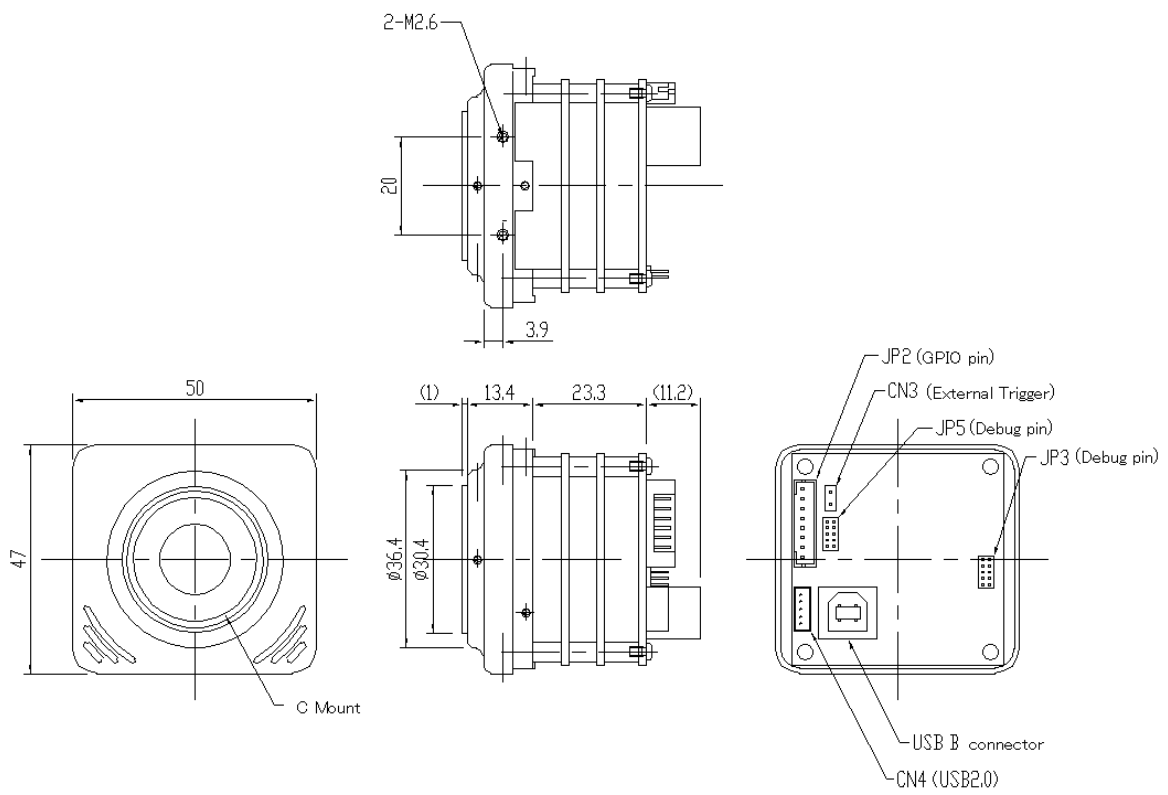

7-5 C-MOUNT, BOARD TYPE

ARTCAM-424KY-WOM-OP-CM / 424KY-BW-WOM-OP-CM

ARTCAM-655KY-WOM-OP-CM / 655KY-BW-WOM-OP-CM

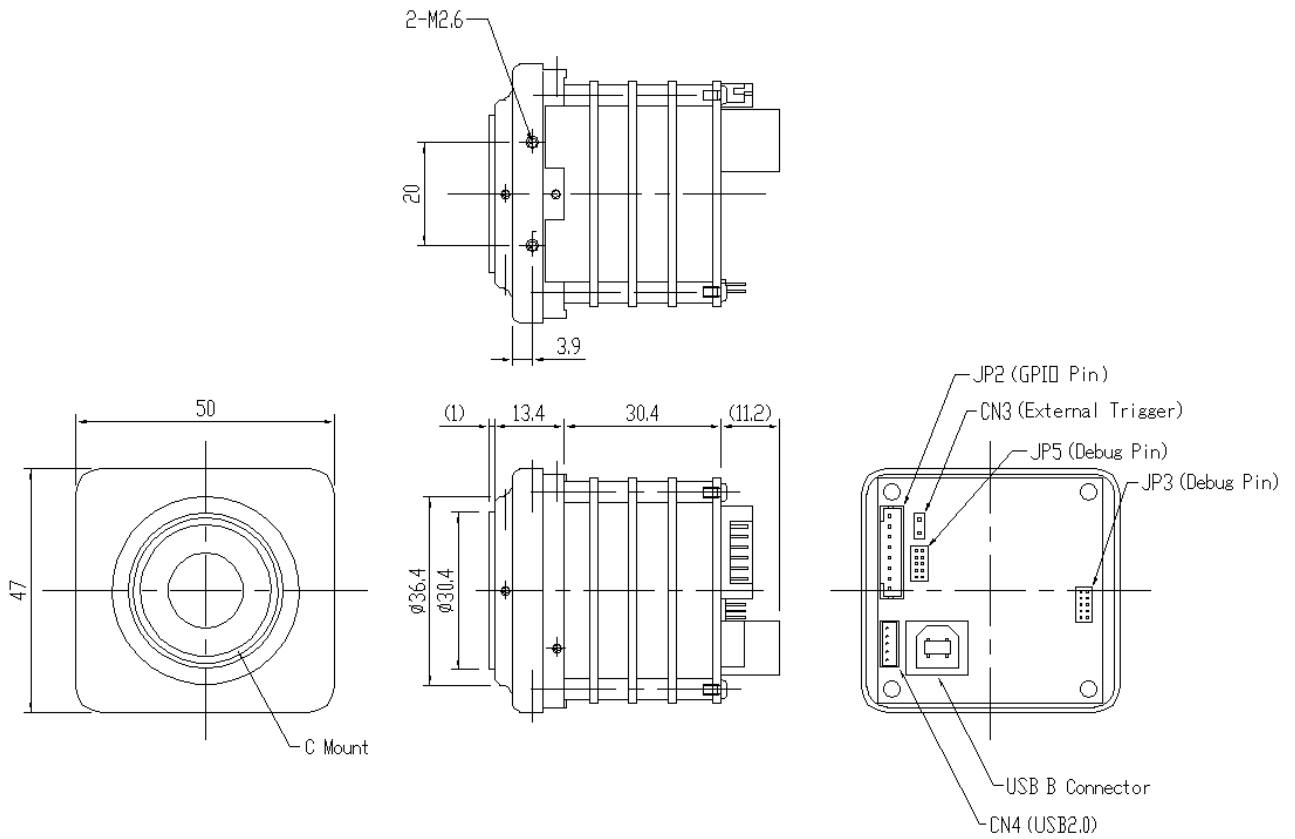

8. Spectral sensitivity characteristics

8.1 ARTCAM-424KY-WOM series(Color model)

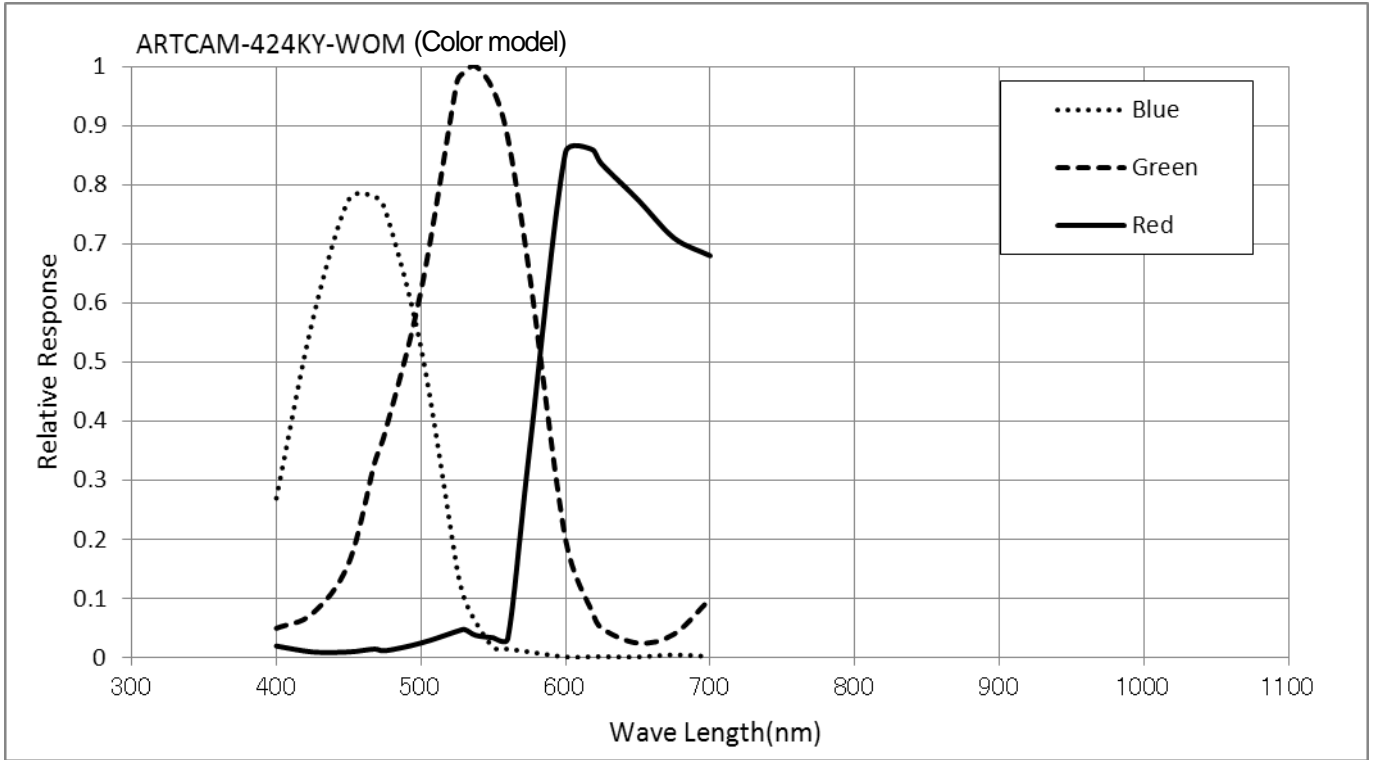

8.2 ARTCAM-424KY-BW-WOM series(Monochrome model)

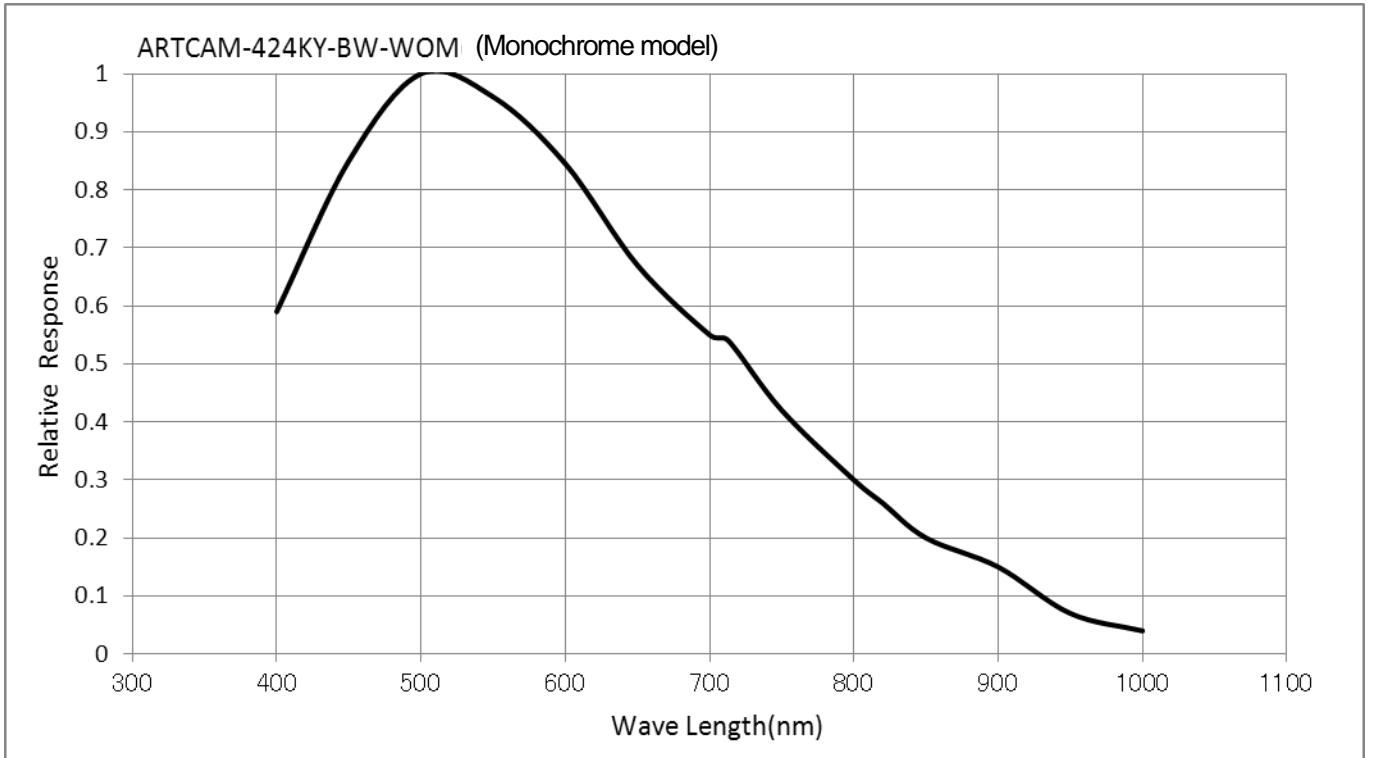

8.3 ARTCAM-445KY2-WOM series(Color model)

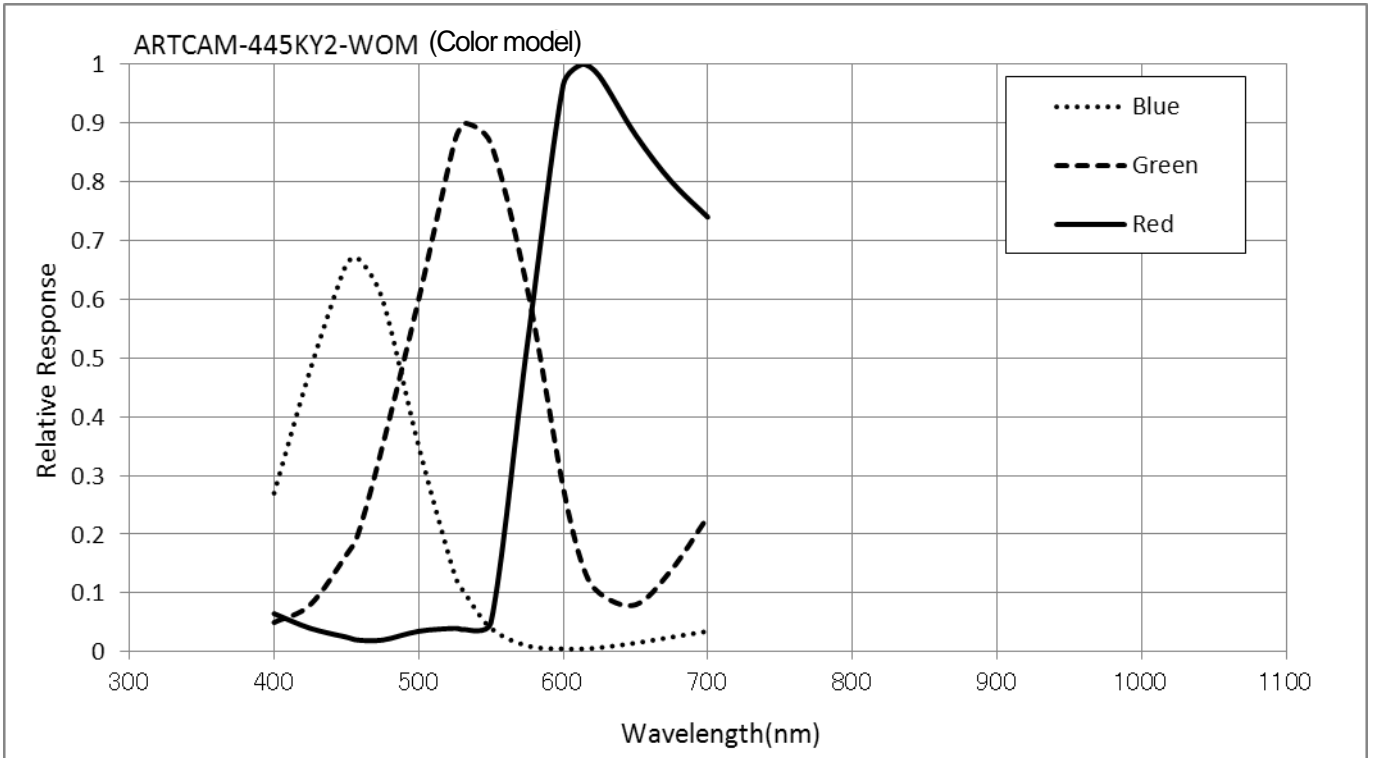

8.4 ARTCAM-445KY2-BW-WOM series(Monochrome model)

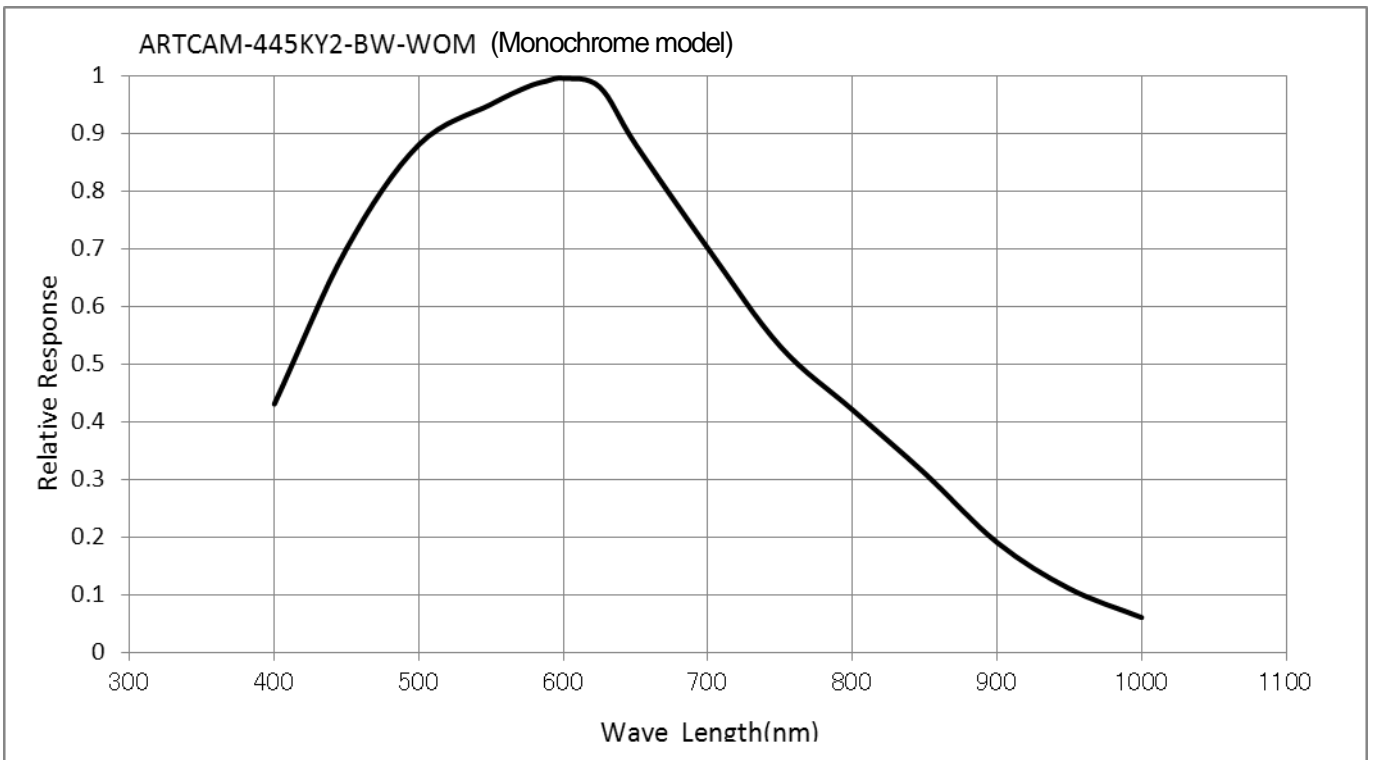

8.5 ARTCAM-150P5-WOM series(Color model)

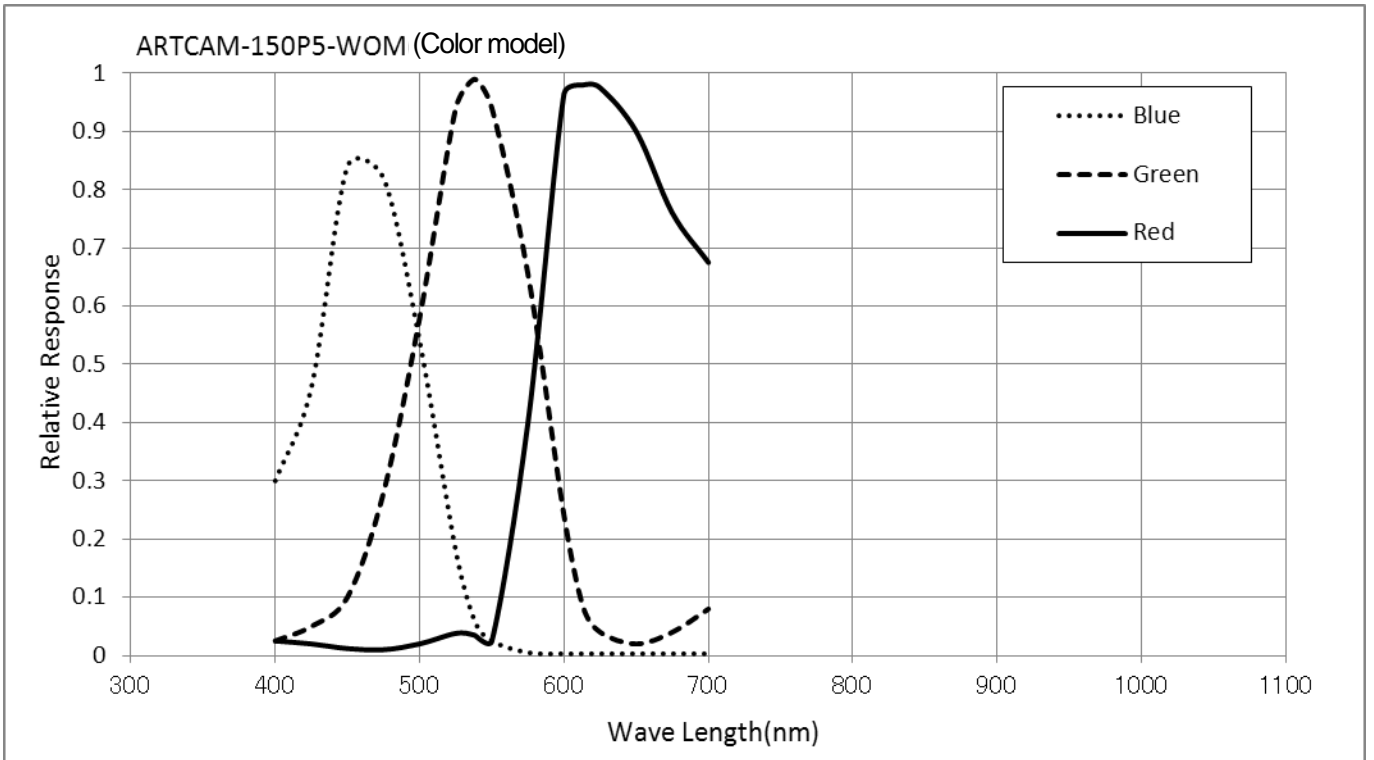

8.6 ARTCAM-150P5-BW-WOM series(Monochrome model)

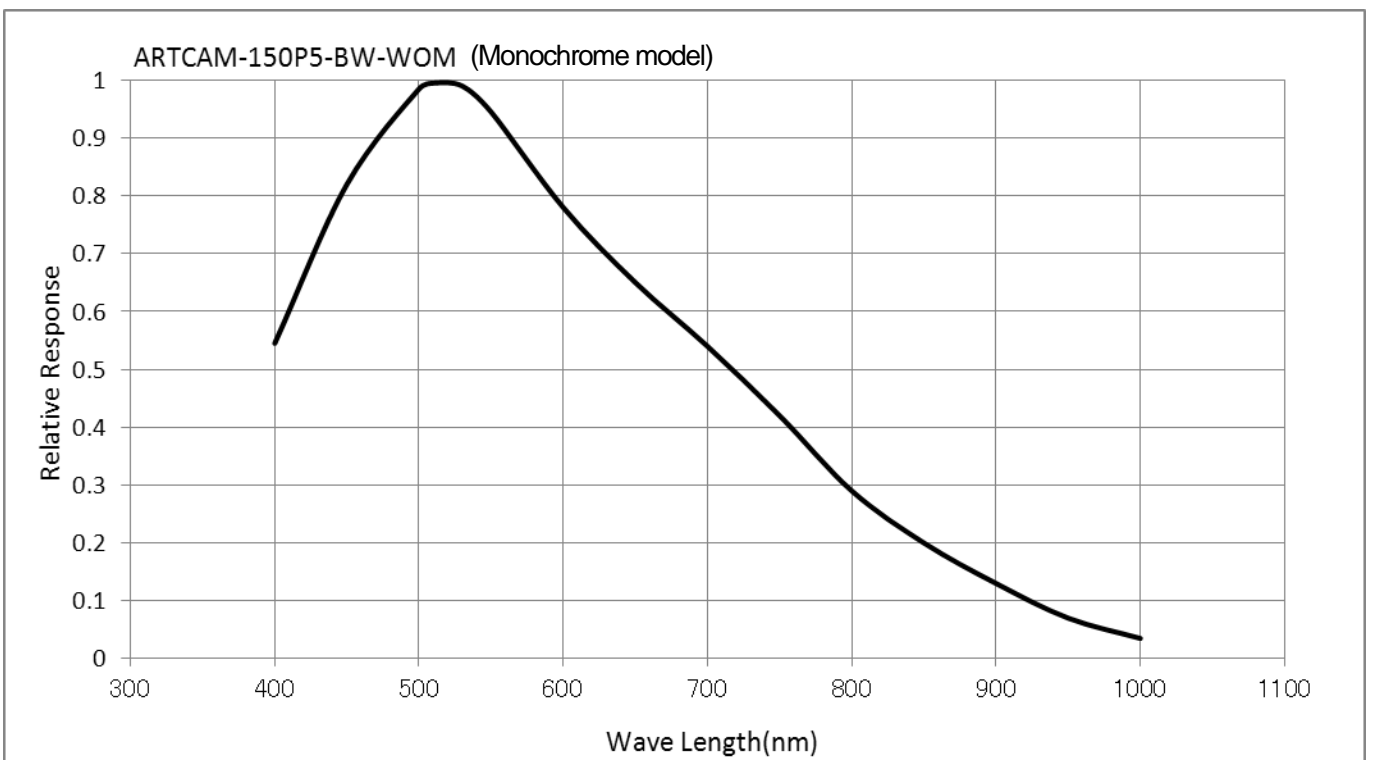

8.7 ARTCAM-285CX-WOM series(Color model)

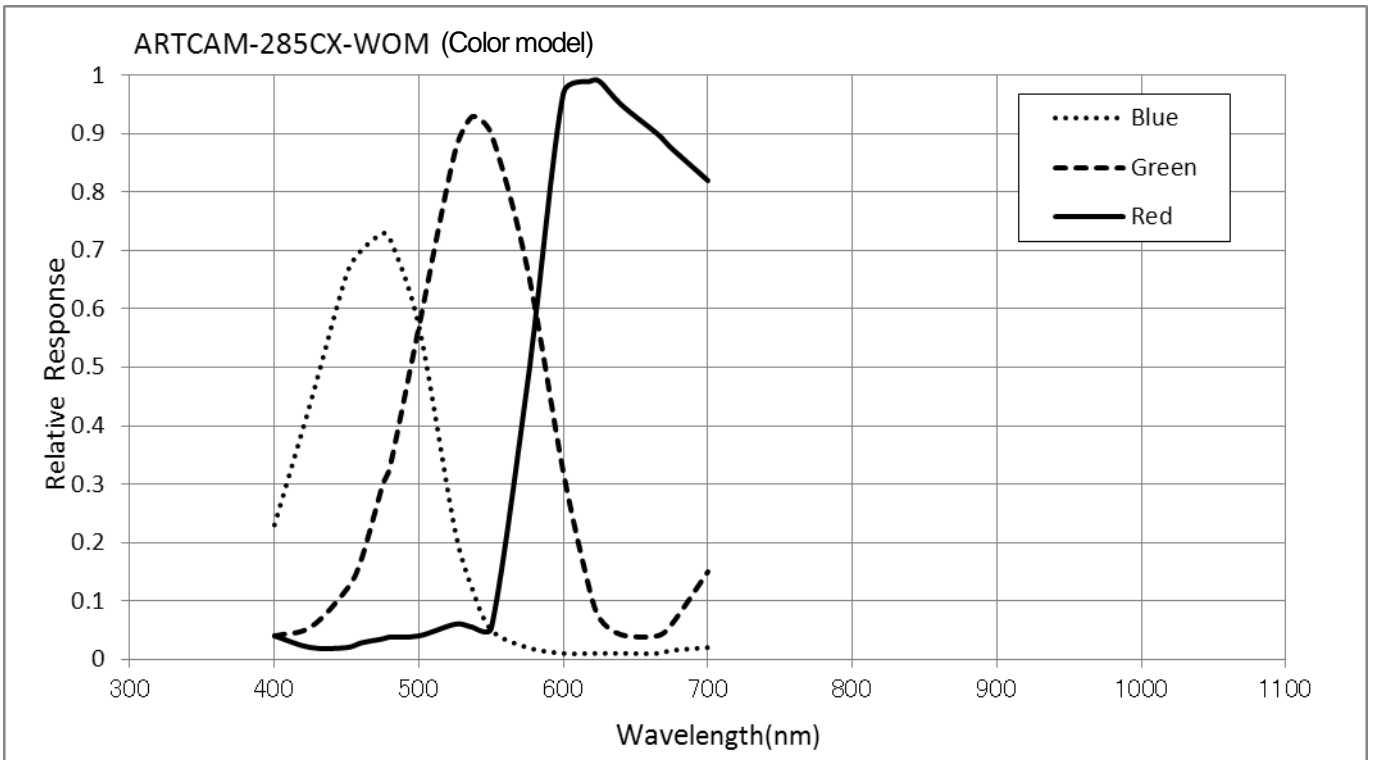

8.8 ARTCAM-285CX-BW-WOM series(Monochrome model)

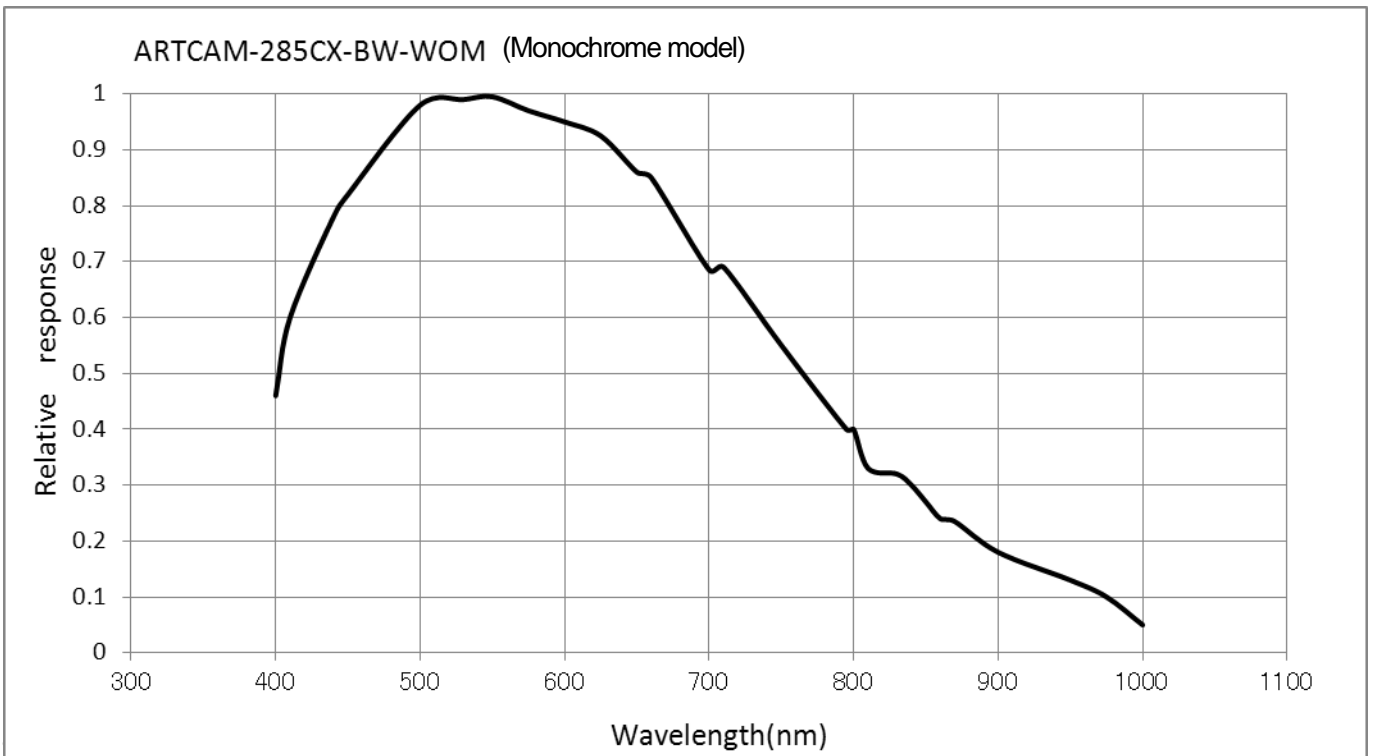

8.9 ARTCAM-274KY-WOM series(Color model)

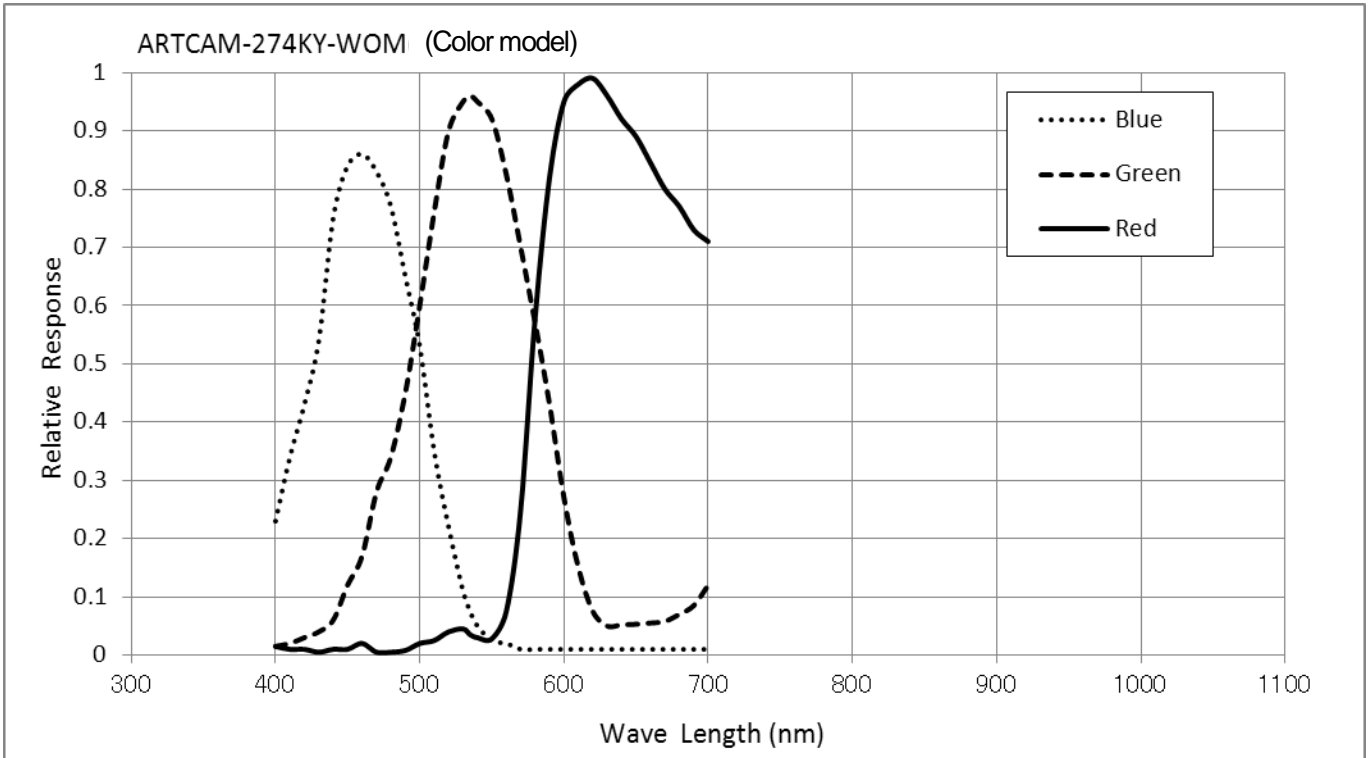

8.10 ARTCAM-274KY-BW-WOM series(Monochrome model)

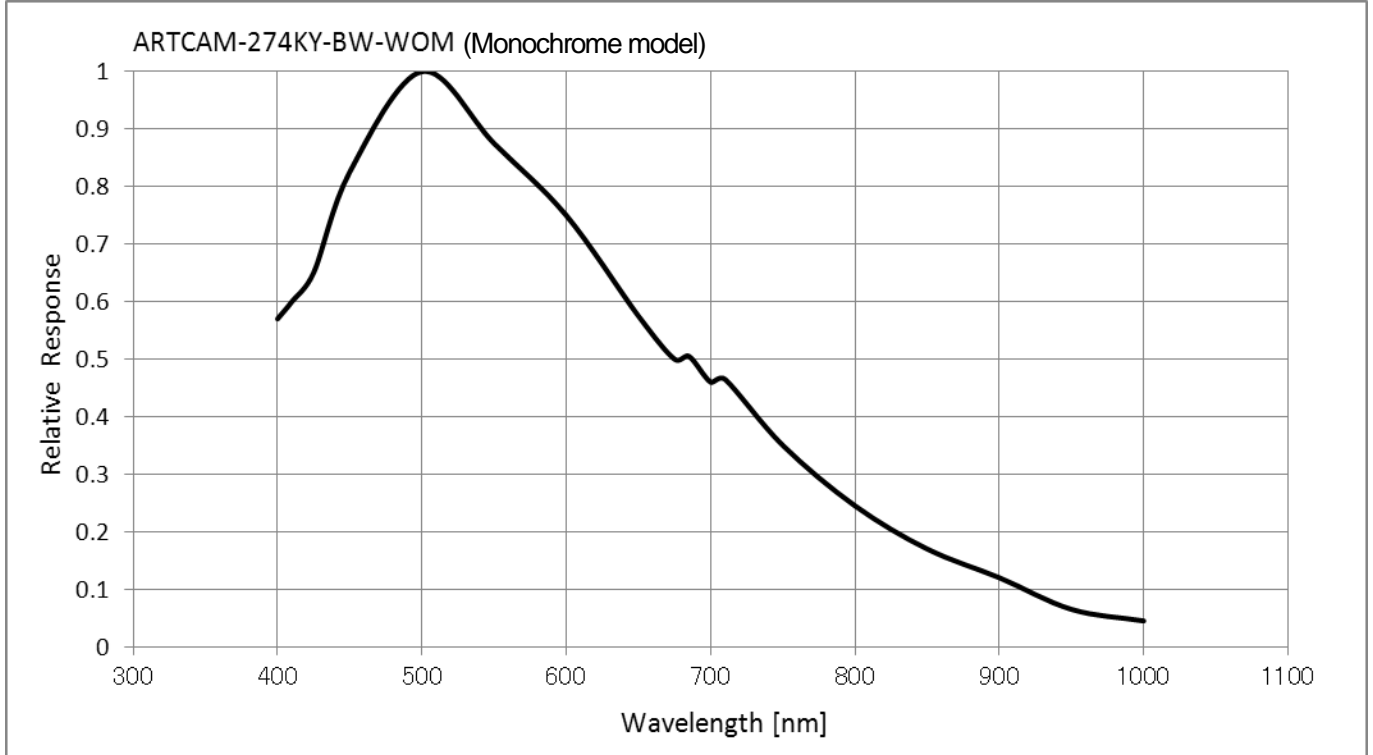

8.11 ARTCAM-500P II -WOM series(Color model)

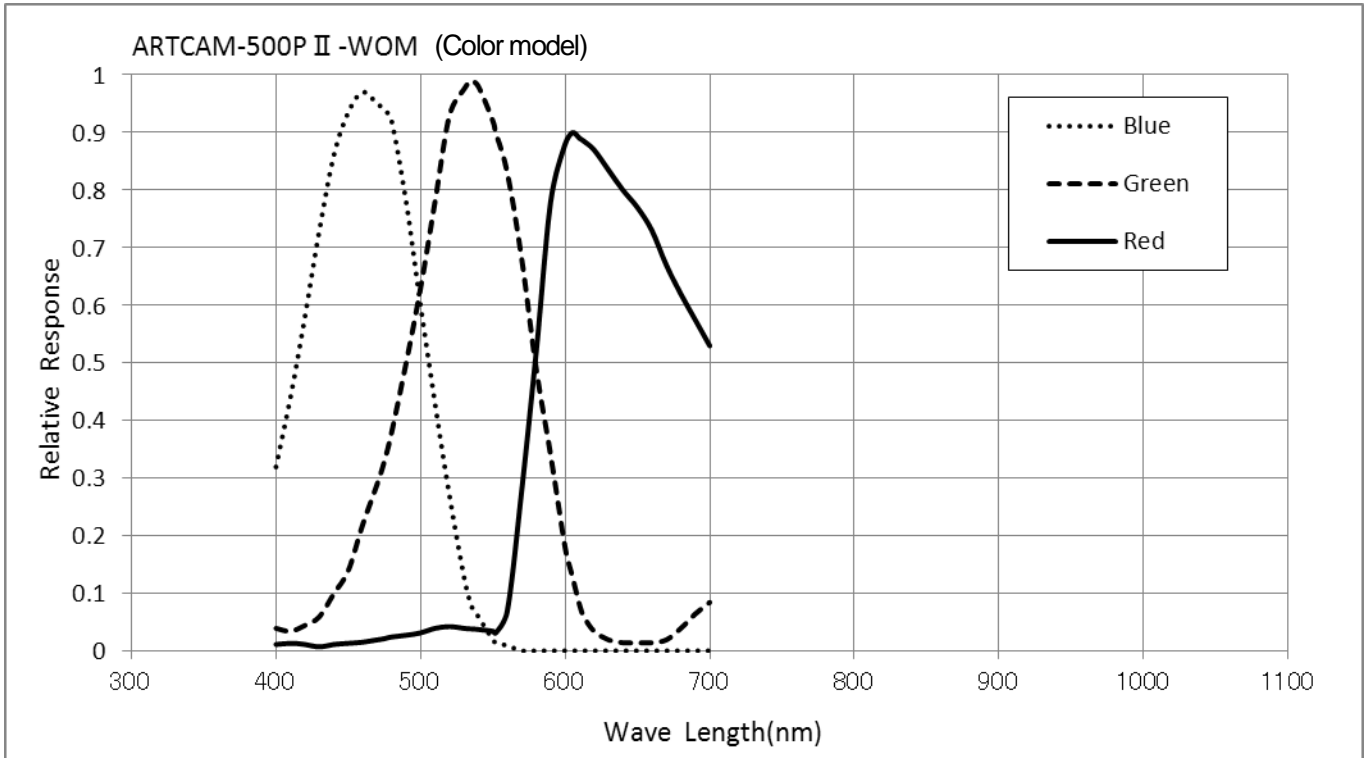

8.12 ARTCAM-655KY-WOM series(Color model)

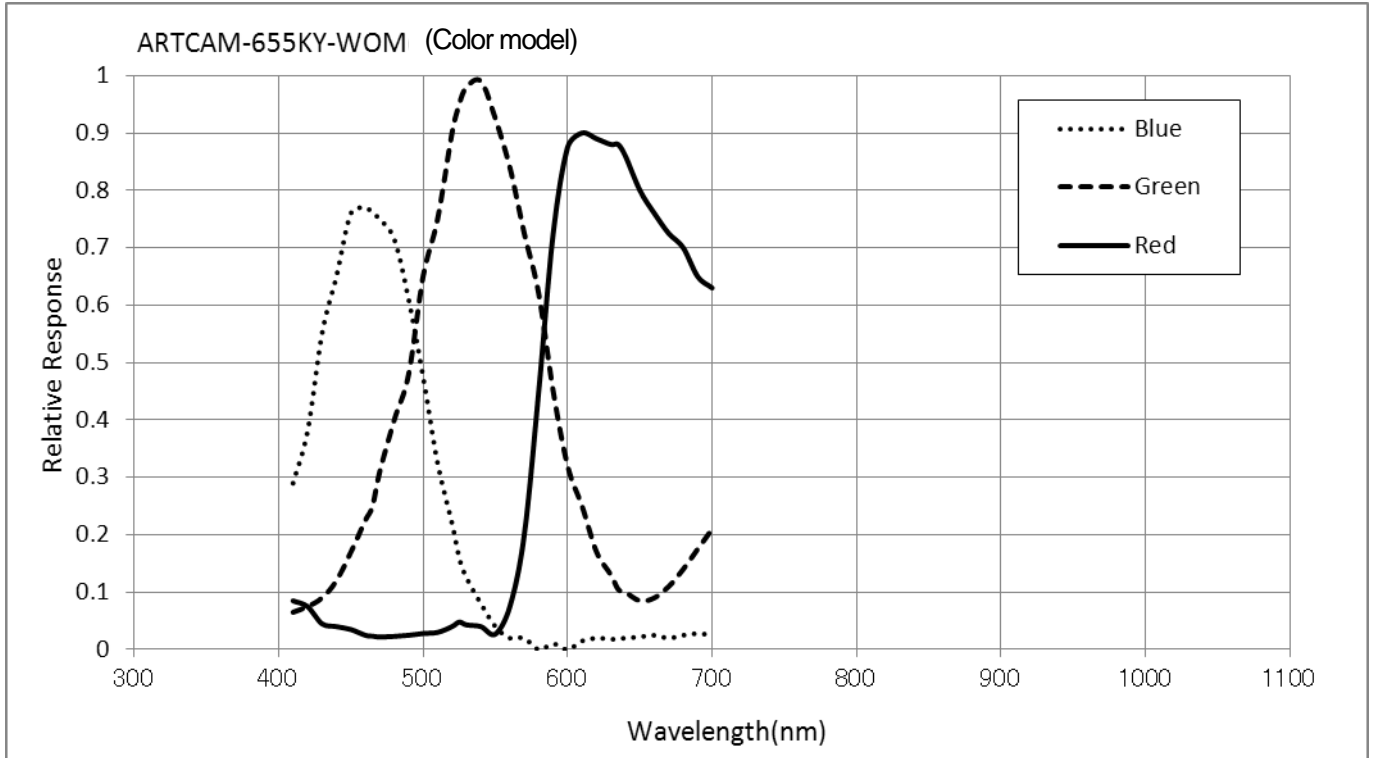

8.13 ARTCAM-655KY-BW-WOM series(Monochrome model)

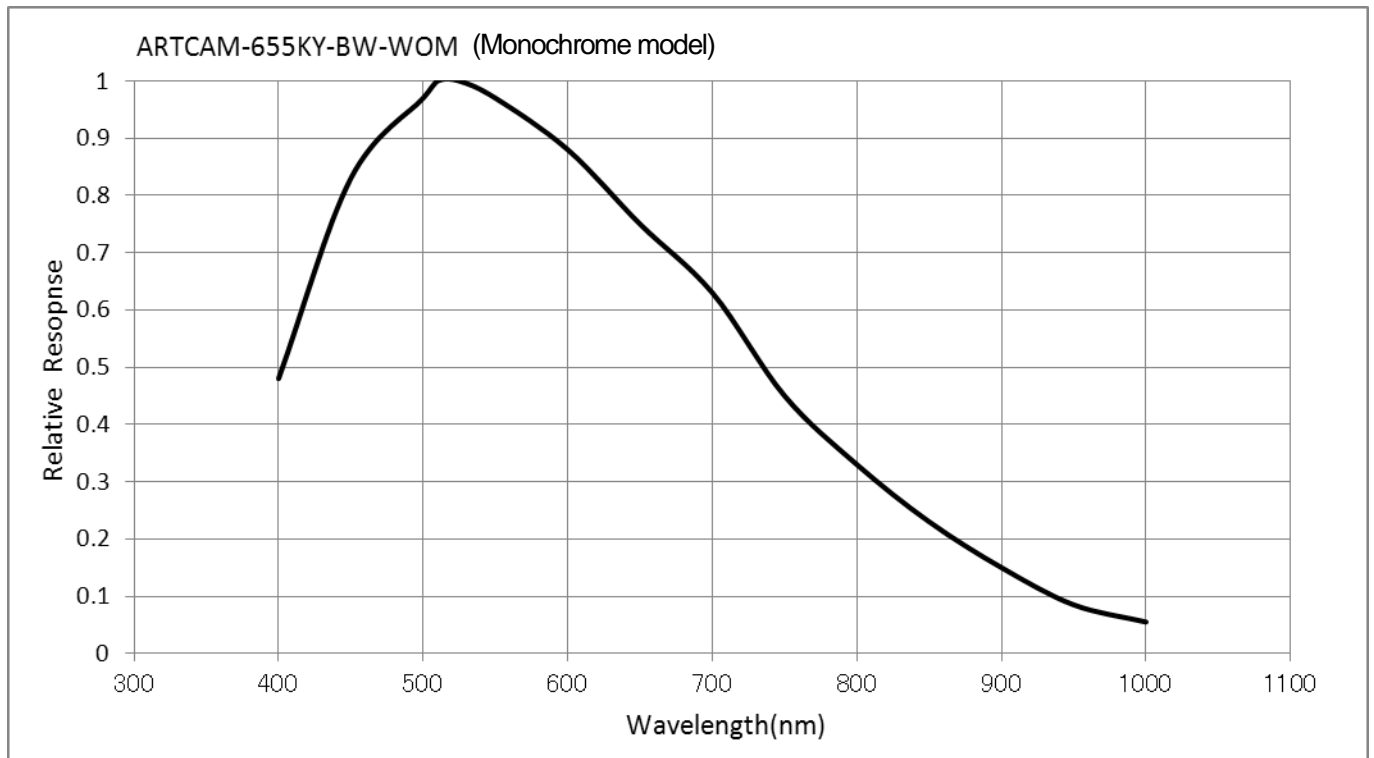

9. AD Conversion (ARTCAM-WOM series)

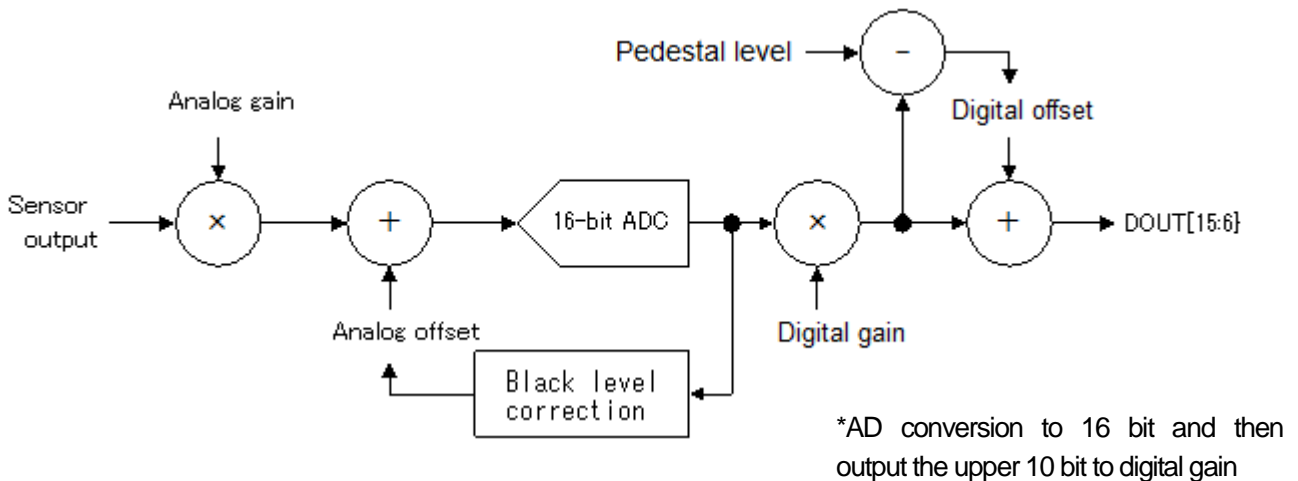

9-1 Standard functions (configurable in standard viewer/SDK)

- Digital gain

Global gain (digital gain) can be configured with the standard viewer software or SDK.

Setting range on standard viewer software: 0 - 1023

Default value on standard viewer software: 512

Digital gain = gain value x 0.03125 - 6.0 (dB)

Example 1: When default value is 512,

Analog gain = $512 \times 0.03125 - 6.0 = 10$ (dB)

9-2 Optional functions (please contact us for further details.)

- Analog gain:

Can be set to -3dB, 0dB, 6dB, 12dB or 18dB

- Black level correction

By default, black level correction is set automatically, and the Pedestal level is set to 32 at 10bit.

(When output is at 8bit, the Pedestal level is approximately $32 / 4 = 8$.)

The target value of Pedestal level (32) can also be modified.

10. Optional Functions

10-1 Trigger Input

ARTCAM-WOM series are designed with external trigger.

Trigger Input Circuit

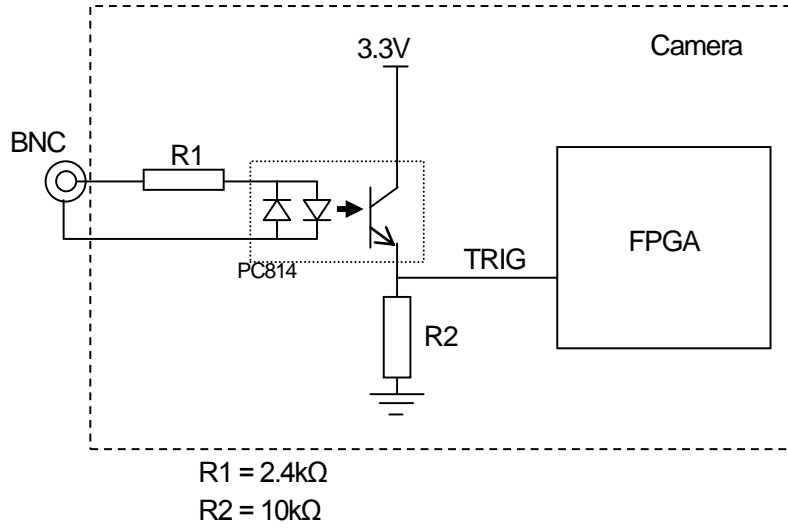

10-2 GPIO

GPIO option is available upon request before the delivery of the ARTCAM-WOM series.

Pin assign

No.	Function
1	GPIO_0
2	GPIO_1
3	GPIO_2
4	VCC(3.3V) Maximum output 50mA
5	GPIO_3
6	GPIO_4
7	GPIO_5
8	Gnd

• Each of the six GPIO pins is pulled up to 3.3V with 1k Ω on the circuit board and is connected to the IO pins on FPGA.

• When GPIO pins are used as output pins, the FPGA output is driven at high impedance and Low level.
(At the time of power-up: high impedance)

To control GPIO, please use the ArtCam_SetIOPort / GetIOPort functions in SDK.

To control GPIO output, please specify the corresponding OR calculated values of each bit as per the table below to the second argument of the SetIOPort function.

IO pin	Bit
GPIO_0	0x01
GPIO_1	0x02
GPIO_2	0x04
GPIO_3	0x08
GPIO_4	0x10
GPIO_5	0x20

For example, to have GPIO_0, GPIO_1, GPIO_4 output High(Z) and GPIO_2, GPIO_3, GPIO_5 output Low, please call this as follows:

```
ArtCam_SetIOPort(hACam, (0x01 | 0x02 | 0x10), 0, 0);
```

To read the GPIO pins, BYTE-type values can be gotten with the GetIOPort function.

For example, to get the status on GPIO_4 pin, please call the followings:

```
BYTE data = 0x00;  
ArtCam_GetIOPort(hACam, &data, 0, 0);  
BOOL gpio4 = (data & 0x10) ? TRUE : FALSE;
```

And the BOOL-type variable gpio4 of GPIO_4 pin is gotten

• Extensions

Monitoring the vertical synchronization signals, horizontal synchronization signals, strobe signals, and trigger signals on the sensor are possible as extensions of the GPIO option. (Optional)

