

USB2.0 NIR CMOS CAMERA

ARTCAM-130HP-WOM series INSTRUCTION BOOKLET

1.3M Pixels ARTCAM-130HP-WOM

Contents

1. Attention.....	3
2. Introduction.....	6
3. Main Features.....	6
4. The Product.....	8
5. Connect the Camera.....	8
6. Specifications.....	9
7. External Dimensions.....	11
8. Spectral sensitivity characteristics.....	12
9. Characteristic of visible light cut filter	12
10. Optional function.....	13
11. Recommended PC.....	14

1. Attention

■ About this manual

1. Before using the camera, please read this manual thoroughly.
2. Please keep this manual reachable and always refer to the contents when needed.
3. Please contact us if the manual is lost or damaged. We will provide a replacement.
4. We cannot guarantee the safety of improper uses of the camera.
5. For your safety, please follow the directions of this manual.
6. All contents are subject to change.
7. Images in this manual may have been simplified to be easier comprehended.
8. Please contact us if you find any unclear points or mistakes in this manual.
9. Quoting, copying or altering some or all parts of the manual without our permission is prohibited.
10. We are not responsible for any lost or damages on your profits due to the use of our products.
11. Please understand that our oversea branches do not provide maintenance or repair services.

■ About the Icons

To keep the safety of the user, other people and their properties, please pay attention to the following icons.



Warning

If the user fails to follow the instruction, physical injury on human or damages on hardware may occur.



Caution

If the user fails to follow the instruction, serious injury or death may occur.

■For Safe Use



Warning

●In following circumstances, please stop using the product and turn off the power immediately to prevent the risks of fires and electric shocks. If the product is defective, please contact us for repair or exchange. For your safety, please do not disassemble, modify or repair the camera on your own.

Please stop using the product and turn off the power immediately when :

- The product becomes smoky or gets extremely hot on the surface, or makes unusual smells or sounds.
- Foreign material or water gets into the product.
- The product falls and becomes damaged.

●Do not place the product on unstable surfaces. The product may be fallen and people may get hurt.



Caution

●Do not expose the product to steam or fumes to avoid electric shocks and fires.

●Do not leave the product in high temperature places such as inside of vehicles or under direct sunlight. High temperature may cause damages to the camera, or even cause fires.

●Do not cover the product with cloth or other materials. The product may get extremely hot and the heat may cause deformations on the parts or even cause fires.

●Please avoid dropping or shocking the product as the product may be damaged.

●Do not touch the cable with a wet hand. Such action may cause electric shocks.

●Please avoid continuously contacting the surface of the camera to your skin when the camera is being used. The surface temperature of the camera may cause burns.

■Other Notices

●Please do not use the camera under strong lights such as sun light for a long period. Also please do not expose the camera under strong lights even when the product is not being used because the sensor might be damaged.

Maintenance

● Wipe the dirt on surface with soft cloth or tissue paper. Do not use alcohol, thinner or benzene to avoid damaging the surface paints.

Electro Magnetic Interference

●The camera may interference with electronic devices such as TV and radio. Please do not place the camera next to such equipment.

■Export Control

The Government of Japan controls military sensitive goods and technologies including relevant dual-use goods and technologies.

This product is a Catch-all Control item subject to the Foreign Exchange and Foreign Trade Act and its relevant legislations. Except for exporting to the 27 white countries designated in the Cabinet Order, export licenses are required if the products are going to be used for military use or if the end user of the product is related to all kinds of military activities. If your circumstances cause the need to apply export licenses, please notify us before you place orders. Also, please notify us in advance if the end users or purposes of use change after the purchase and thus cause the need to apply export licenses.

*The 27 white countries not under the UNSC Arms Embargo :

Argentina, Australia, Austria, Belgium, Bulgaria, Canada, Czech Republic, Denmark, Finland, France, Germany, Greece, Hungary, Ireland, Italy, Republic of Korea, Luxemburg, Netherlands, New Zealand, Norway, Poland, Portugal, Spain, Sweden, Switzerland, United Kingdom, and United States

About the Japanese Security Export Controls, please refer to the webpage for Security Export Control Policy, The Ministry of Economy, Trade and Industry :

<http://www.meti.go.jp/policy/anpo/englishpage.html>

■Guarantee

To save the environment, we do not issue warranty in printed format. Instead, all records of the warranty periods, delivery dates and the customer information are well kept in our system.

For more details, please refer to the sites below :

Hardware Warranty : [http : //www.artray.us/download/artray_warranty.pdf](http://www.artray.us/download/artray_warranty.pdf)

2. Introduction

ARTCAM-130HP-WOM Series is CMOS cameras for industrial use.

Sensor adopts high sensitivity in the near-infrared made by HAMAMATSU Photonics.

ARTCAM-130HP-WOM series adopts USB2.0 interface, so image data can be delivered to PC directly without a capture board. Also, this camera is equipped with an on board memory which avoid data missing during transfer.

3. Main Features

- High near-infrared sensitivity

In addition to visible light, even at high sensitivity in the near-infrared, it is best to get use of near-infrared image.

To perfectly acquire near-infrared image, visible cut filter built-in model (ARTCAM-130HP-NIR-WOM) is also available.

- High resolution.

ARTCAM-130HP-WOM uses a higher resolution sensor of 1.3M pixel and delivers image at 8 frame/second

- USB2.0 Interface

This camera adopts USB2.0 interface, so the data can be delivered to PC directly. No capture board is needed.

- Compact and lightweight

Easy installation to various kinds of equipment.

- ROI (Region Of Interest)

One major benefit of CMOS sensor is the ROI function which enables readout of designated partial images with a faster transmission speed.

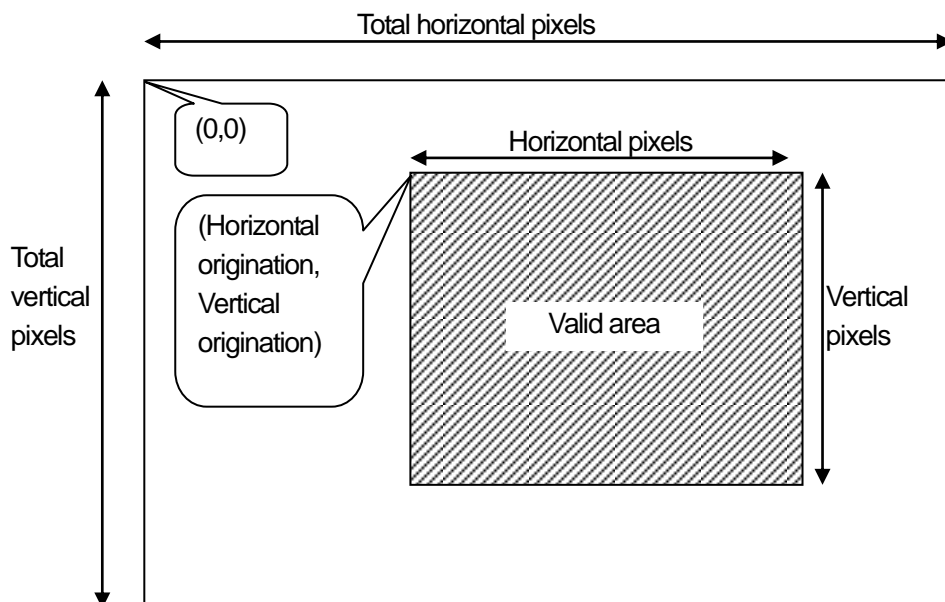

- Global shutter

Equipped CMOS sensor and adopted a global shutter suitable for machine vision.

- Included Viewer Software

ART-Viewer (Windows XP/Vista/7/8).

Users can easily preview, save images and change camera settings by ART-Viewer.

- 2D Measurement & Filing Software(Optional)

Useful 2D measuring functions are available with the optional 2D Measuring & Filing Software - ART-MEASURE.

- Recording Software(Optional)

The optional recording software - ART-REC allows the user to save movies in AVI format.

- Software Development Kit

For customer who prefers to create their own image processing software or use our camera with other applications, we provide SDK upon requests.

4. The Product

- 1) Camera
- 2) USB2.0 Cable A to B connector 3m
- 3) Introduction Booklet
- 4) Viewer software/Device Driver CD
- 5) Software Development Kit [ARTCCM-SDK]

<Options>

- 1) C Mount lens
- 2) 2 Measurement & Filing Software [ART-MEASURE]
- 3) Recording Software [ART-REC]
- 4) 5m extension cable with USB2.0 repeater

5. Connect the Camera

5-1 How to connect a camera

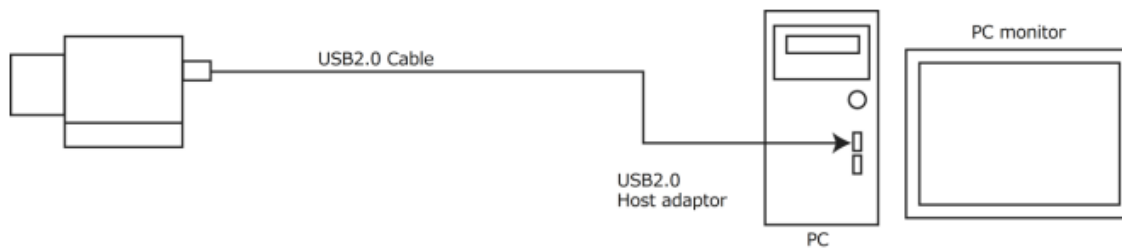

5-2 Shutter Speed

Shutter speed can be changed on the standard viewer software ART-Viewer.

The shutter speed is set directly on the sensor register, so please refer to the following formulas for the real exposure time.

Model	Method
ARTCAM-130HP-WOM	Range :1~8152 (Exposure Time:1/8651~1.06sec) Exposure Time=Shutter Value×115.2 [μsec] ※When drive at 1280×1024 pixels, 25MHz

6. Specifications

6-1 Monochrome Model

Model	ARTCAM-130HP-WOM
Sensor Type	CMOS Monochrome Image Sensor, HAMAMATSU Photonics Model: S11661
Active Pixels	1280 (H)×1024(V)
Resolution	1280 (H)×1024(V)
Active Imager Size	9.472(H)×7.578(V)mm 2/3 inch
Scan Mode	Progressive Scan
Pixel Size	7.4(H)×7.4(V)μm
Shutter Type	Global Shutter
Frame Rate	8fps
Shutter Speed	1/8651 ~ 1.06s
Interface	USB2.0 Bulk Transfer
Synchronization System	Internal Synchronization
Lens Mount	C Mount
Power	DC5V(Supplied by USB port)
Power Consumption	Under Approx.2W
Ambient Conditions	Operating Temperature/Humidity : 0 ~ 35°C/10 ~ 80%(Non condensing) Storage Temperature/Humidity : 0 ~ 60°C /10 ~ 95%(Non condensing)
External Dimensions	50(W)×47(H)×41.7(D)mm ※Lens, tripod plate are not included
Weight	Approx.110g ※ Tripod plate, cable are not included

6-2 NIR Model

Model	ARTCAM-130HP-NIR-WOM
Sensor Type	CMOS Monochrome Image Sensor, HAMAMATSU Photonics Model: S11661
Active Pixels	1280 (H)×1024(V)
Resolution	1280 (H)×1024(V)
Active Imager Size	9.472(H)×7.578(V)mm 2/3 inch
Scan Mode	Progressive Scan
Pixel Size	7.4(H)×7.4(V) μ m
Shutter Type	Global Shutter
Frame Rate	8fps
Shutter Speed	1/8651 ~ 1.06s
Interface	USB2.0 Bulk Transfer
Synchronization System	Internal Synchronization
Lens Mount	C Mount
Power	DC5V(Supplied by USB port)
Power Consumption	Under Approx.2W
Ambient Conditions	Operating Temperature/Humidity : 0 ~ 35°C/10 ~ 80%(Non condensing) Storage Temperature/Humidity : 0 ~ 60°C /10 ~ 95%(Non condensing)
External Dimensions	50(W)×47(H)×41.7(D)mm ※Lens, tripod plate are not included
Weight	Approx.110g ※Tripod plate, cable are not included

7. External Dimensions

7-1 C-MOUNT, CASED CAMERA ARTCAM-130HP-WOM/130HP-NIR-WOM

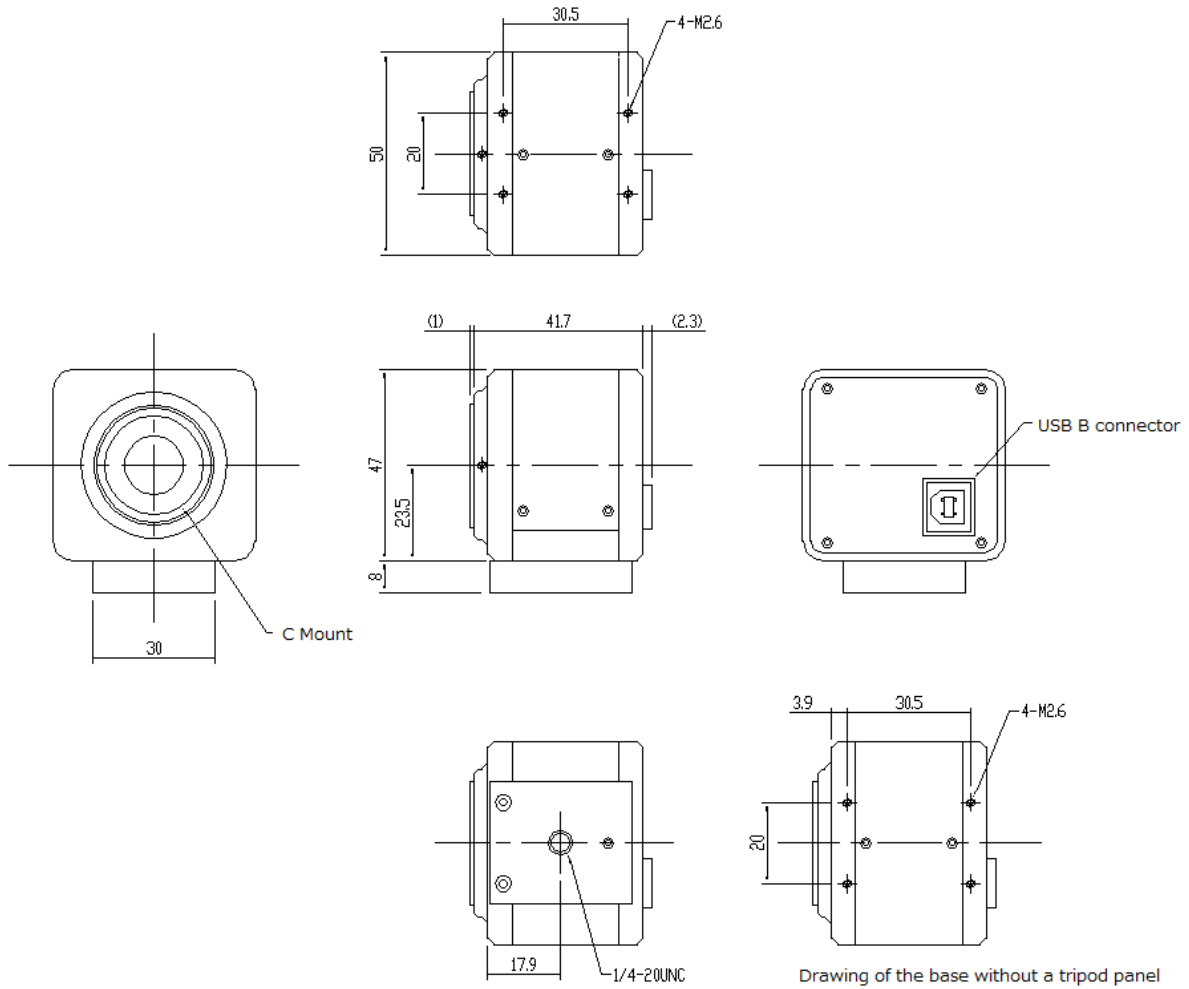

8. Spectral sensitivity characteristics

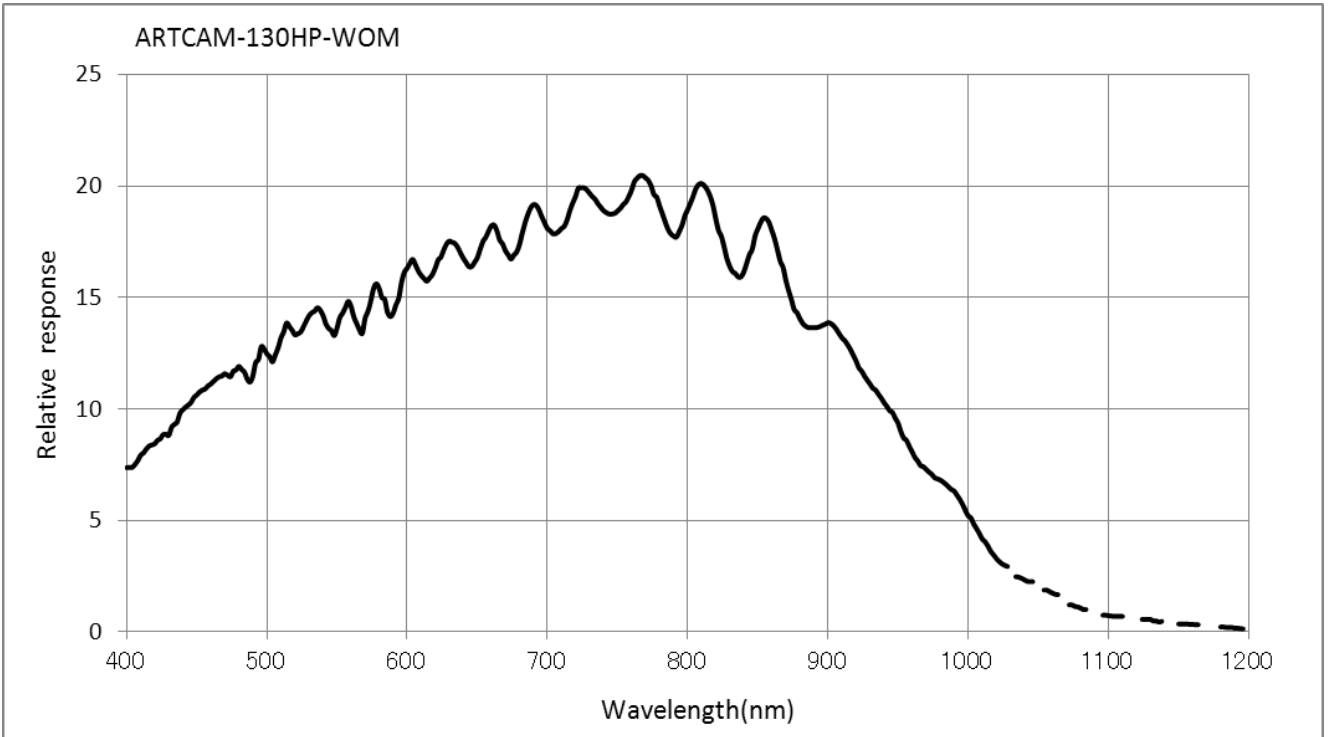

9. Characteristic of visible light cut filter

ARTCAM-130HP-NIR-WOM is adopting R70 on visible cut filter.

Please check the spectral sensitivity characteristic of image sensor as well.

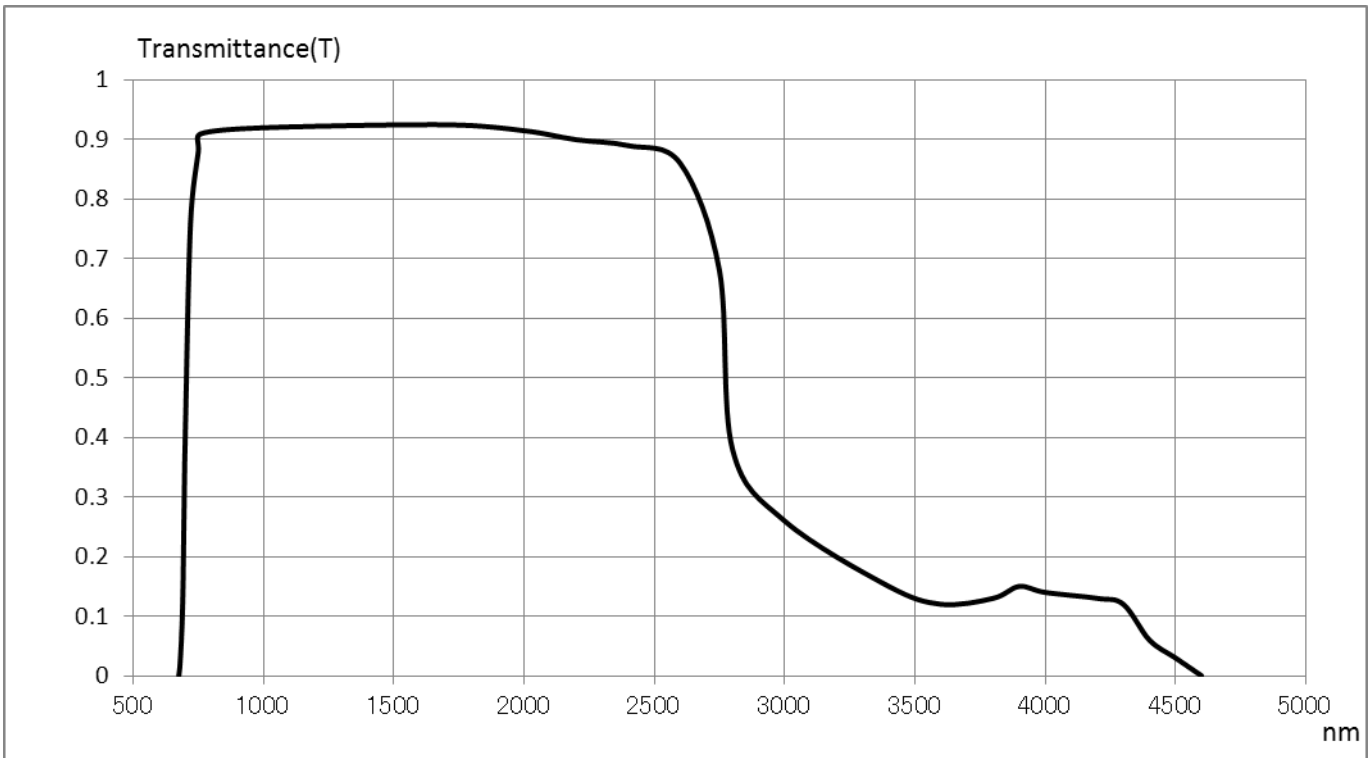

11. Optional Functions

11-1 External trigger function

ARTCAM-130HP-WOM series are designed with external trigger.

※Please contact us if you need this function.

Trigger input circuit diagram

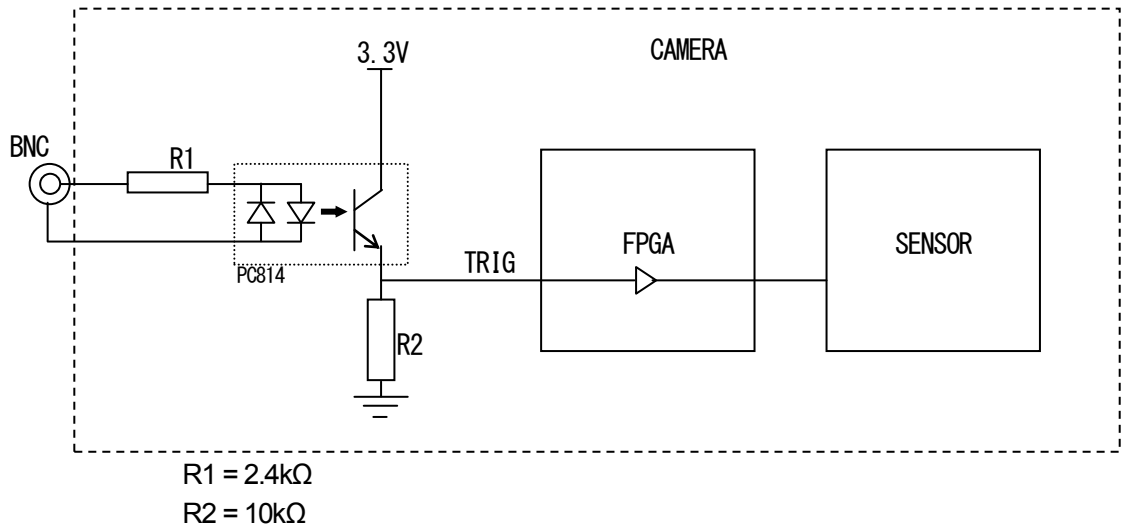

12. Recommended PC

12-1 Recommended System Requirements

- Intel chip set, ICH series (\geq ICH6)
- CPU: Intel Core2duo 2.4GHz or higher
- Memory: \geq 512MB
- OS: \geq Windows XP

12-2 Minimum System Requirements

- USB2.0 Enhanced Host Controller
- CPU: Intel Pentium4 1.7GHz or higher
- Memory: \geq 256MB
- OS: \geq Windows XP



Caution

■Please refer the restrictions below when you use ARTCAM.

(1)Recommended System requirements

If the system specifications are below the recommended requirements, it is possible that the camera may not reach the maximum speed.

(2) Use of other USB3.0 hardware

The data on our camera/converter is transferred in bulk mode. For this reason, when using our camera/converter, please avoid using other bulk transferred USB3.0 hardware such as Memory stick, External HDD, External DVD, CDROM and etc.

As a solution, we recommend to install a PCI USB host card to the PC and connect external USB hardware to this port only.

(3) USB3.0 cable Extension

We cannot guarantee the functionality of the USB3 camera if the user adopts USB3.0 extension cables or repeaters which are not confirmed by us. With the extension cables or repeaters, the bandwidth of transfer may differ, and thus caused malfunctions such as a low frame rate or recognition failure on the camera.

What may cause the problem is that the regulation of the power lines becomes not enough, and so causes impedance mismatch on data signals.

*For the recommended extension cable, please contact our sales department. (TEL : +81-3389-5488)



44 100 16 82 0167

ARTRAY CO., LTD.

1-17-5 Kouenjikkita, Suginami-ku, Tokyo 166-0002 Japan

Tel : +81-3-3389-5488

Fax : +81-3-3389-5486

Email : sales@artray.us

URL : www.artray.us